

**Findings.** A new method for the LLV longitudinal stability ensuring is proposed, and a computational method for the design parameters of vibration dampers sets is developed by using the combinatorial algorithm of exhaustive search at the complete uncertainty of the longitudinal oscillations attenuation parameter (decrement) of LLV structure.

**The originality.** A new method has been developed to ensure the LLV longitudinal stability either a tandem or package composition, belonging to the medium and heavy class. For moments of time sensitive to the loss of longitudinal stability, the possibility of effective use of longitudinal displacements of the layers of the fuel tanks liquid filler that arise as a result of the interaction of the liquid masses of the fuel and oxidant with the walls and bottoms of its tanks experiencing deformations during the occurrence of longitudinal oscillations of the liquid fuel tanks structures. A generalized method of the optimal parameters calculating for the location of the proposed damper sets for longitudinal oscillations has also been developed. The calculations were first carried out by using an unconventional combinatorial exhaustive search algorithm.

**Practical implications.** The researches allow us to develop a new design of the calming longitudinal oscillations means to the tandem and packet package of LLVs that are classified as medium and heavy, and, with a sufficient accuracy for the practical application, to calculate the optimal values of the design and positional parameters of the longitudinal vibration dampers for such LLVs, so that with the minimum values of its own weight, the goal was achieved of the longitudinal stability fully ensuring of the above-mentioned LLVs even at the start point of their designing.

**Keywords:** *liquid launched vehicle (LLV), liquid-propellant engine (LPE), longitudinal mode, shock absorber, firmness, decrement, dampener, fuel tank, combinatorial algorithm, computer.*

УДК 621.39.004.021

© А.В. Гавриш, Д.Л. Колосов

## **ЧИСЕЛЬНЕ МОДЕЛЮВАННЯ ГІДРОУДАРНИХ ЯВИЩ ТА ЇХ ГАСІННЯ В ТРУБОПРОВОДАХ ПІД ТИСКОМ ПРОМИСЛОВОГО ПРИЗНАЧЕННЯ**

© A. Ghavrish, D. Kolosov

## **THE HYDRAULIC IMPACT AND ALLEVIATION PHENOMENA NUMERIC MODELING IN THE INDUSTRIAL PUMPED PIPELINES**

**Мета.** Розробка математичної гідродинамічної моделі перехідних процесів потоку робочої рідини в системі промислового трубопроводу, що містить насос і демпфер, з врахуванням жорсткості та шорсткості його стінок при імітації різкої зупинки цього потоку шляхом закриття заслінки на його віддаленому кінці, з подальшим впровадженням цієї моделі для використання у вигляді програмного комплексу на основі учбової версії пакету Matlab.

**Методика дослідження.** Розрахунок перехідних процесів та частотних характеристик дільниці трубопроводу великої довжини, в гідромеханічну систему якого підключено роторний насос та демпфер, побудовано на базі нелінійної математичної моделі модифікованих рівнянь Нав'є-Стокса. Моделювання швидкого перекриття потоку проведено з використан-

ням математичного моделювання роботи промислових заслінок через експоненціальний закон зменшення площі поперечного перетину трубопроводу.

Основою чисельного моделювання є метод характеристик, який застосовано для вирішення вказаних рівнянь Нав'є-Стокса. Отримані в результаті перетворень нелінійні диференціальні рівняння вирішуються за допомогою методу кінцевих різниць першого роду.

**Результати дослідження.** Розроблено математичну модель для прогнозування пікових амплітуд тиску, що виникають через дію різних гальмівних чинників, які спричиняють зворотньо-поступальний масовий потік робочих рідин. З використанням цієї моделі створено й налагоджено програмний обчислювальний комплекс, який доведено до моделюючого програмного забезпечення (ПЗ) робочої станції на базі персонального комп'ютера з встановленою операційною системою (ОС) Windows Vista, Windows 7, 10.

**Наукова новизна.** Запропоновані методи чисельного інтегрування системи рівнянь Нав'є-Стокса на просторово-часовій сітці за допомогою методу характеристик дозволили перейти до практичного чисельного моделювання та отримання значень параметрів течії робочих рідин в трубопроводах великої довжини з врахуванням граничних умов для стикових перетинів, що визначають поведінку насосів, діафрагм, заслінок, демпфуючих пристроїв, які підключаються до вказаних перетинів вказаного трубопроводу.

**Практичне значення.** Проведені практичні розрахунки показали їх повну придатність для отримання необхідних оціночних значень параметрів течії при числовому моделюванні перехідних процесів та визначенні прийнятних параметрів демпферного пристрою, необхідного для гасіння гідроударних явищ, що можуть виникати при раптовому закритті прохідного перетину трубопроводу за допомогою заслінки, що встановлена на віддаленому кінці вказаного трубопроводу великої довжини.

**Ключові слова:** промисловий трубопровід, демпфер, програмне забезпечення (ПЗ), обчислювальна гідродинаміка (CFD), операційна система (ОС), перехідний процес, метод характеристик, комп'ютер (ПК), графічний інтерфейс користувача.

**Preamble.** The issues of the hydropercussion phenomena mathematical modeling in the industrial pumped piping systems, with the pumps and dampeners included, to determine the impact absorbers effectiveness on the amplitude-frequency characteristics of these hydro-mechanical systems are considered. It's still actual and many authors are still looking for the systems CFD issues research and resolution, see [6, 7]. Method of calculating the transient and frequency characteristics of the pipeline that contains a pump and a dampener, is based on nonlinear mathematical model. Simulation of overlapping stream with using industrial valves is provided by introducing the exponential law of diminishing cross-sectional area of the pipeline. The basis of calculation is the method of characteristics applied to the simplified Navier-Stokes equations. The resulting nonlinear differential equations are solving by using the finite difference method of first order.

**Purpose** of the article was to develop the mathematical model of hydrodynamic flow of the working fluid in a long discharge pipe considering slackness and roughness of its walls in imitation of a sharp stop this flow by closing the valve at its distal end with the further implementation of this model in a software package based on the Matlab package university version (actually it is the Computational Fluid Dynamics (CFD) problem). On the basis of the mathematical model the task to create a software package, which includes user-friendly graphical interface allows you to use the results of this development in the form of an executable .exe program. In the future,

this program is intended for estimations of the damping devices effectiveness of different parametric configurations on the long lasting industrial pressurised pipeline systems, the characteristics of which input at working procedure through the Windows OS based PC as a workstation by trained personnel of the damping devices manufacturer.

These developments have been carried out under the framework of a scientific mission to the Liquid Dynamics int'l inc company, headquartered in Wilmington area, NC – World wide manufacturer and exporter of damping devices, and on the instructions and order of Dnipro's National Mining University, Ukraine.

**Analysis of existing achievements and publications.** In this article the problem of the damping devices impact estimation to smooth the peak amplitudes of pressure in the hydraulic fluids industrial pipelines under the simulated conditions of hydropercussion processes when the modified method of characteristics are used are considered [1]. The software part of the project was implemented using the built-in programming language of Matlab software package [2].

**The main part of the research.** Method of calculating the transient and frequency characteristics of the pipeline contains the pump and dampener is based on nonlinear mathematical model. Simulation of overlapping stream with using industrial valves is provided by introducing the exponential law of diminishing cross-sectional area of the pipeline. The basis of calculation is the method of characteristics applied to the simplified Navier-Stokes equations. The resulting nonlinear differential equations are solving by using the finite difference method of first order.

To the problem resolving the method of characteristics [3] has been used. The method of characteristics converts partial differential equations, for which the solution can't be written in general terms (as, for example, the equations describing the fluid flow in a pipe) into the equations in total derivatives. The resulting nonlinear equations can then be integrated using the methods of using the equations of finite differences.

Hydraulics equations that embody the principles of conservation of angular momentum and continuity in the one-line pipe, respectively, are as follows:

$$+ \begin{cases} \frac{P_x}{\rho} + VV_x + V - g_t \cdot \sin a + \frac{fV|V|}{2D} = 0 \\ PP_t + P_xV + \rho \cdot a^2 \cdot V_x = 0 \end{cases} \times \lambda \quad (1, 2)$$

These equations can be combined with the unknown factor of  $\lambda$  and obtain the equation:

$$\lambda \left[ P_x \left( V + \frac{1}{\lambda \rho} \right) + P_t \right] + \left[ V_x \left( V + \rho \cdot a^2 \lambda \right) + V_t \right] - g \cdot \sin a + \frac{fV|V|}{2D} = 0 \quad (3)$$

The arbitrary choice of two different values of  $\lambda$  give two independent equations in the variables  $P(x, t)$ ,  $V(x, t)$ , is equivalent to (1) and (2). With a suitable choice of  $\lambda$  the simplification is possible. In particular, since  $P$  and  $V$  are functions of  $x$  and  $t$ , then if we assume that  $x$  - a function  $t$ , then:

$$\frac{dP(x,t)}{dt} = \frac{\partial P}{\partial x} \frac{dx}{dt} + \frac{\partial P}{\partial t} \frac{dt}{dt} = P_x \frac{dx}{dt} + P_t \quad (4)$$

$$\frac{dV(x,t)}{dt} = \frac{\partial V}{\partial x} \frac{dx}{dt} + \frac{\partial V}{\partial t} \frac{dt}{dt} = V_x \frac{dx}{dt} + V_t$$

$$\text{If } \frac{dx}{dt} = V + \frac{1}{\lambda\rho} = V + \rho\alpha^2\lambda, \quad (5)$$

then equation (3) becomes an ordinary differential equation:

$$\lambda \frac{dP}{dt} + \frac{dV}{dt} - g \sin a + \frac{fV|V|}{2D} = 0 \quad (6)$$

Solving (5), we obtain:  $\lambda = \frac{1}{\rho\alpha}$ ,  $\frac{dx}{dt} = V + a$  - downstream,

$$\lambda = \frac{1}{\rho\alpha}, \quad \frac{dx}{dt} = V + a \text{ - upstream} \quad (7)$$

Substituting equation (7) (6), we obtain a system of total differential equations:

$$\frac{dP}{dt} + \rho\alpha \frac{dV}{dt} - \rho\alpha g \sin a + \rho\alpha \frac{fV|V|}{2D} = 0, \quad (8)$$

$$\frac{dx}{dt} = V + a, \quad (9)$$

$$\frac{dP}{dt} - \rho\alpha \frac{dV}{dt} + \rho\alpha g \sin a - \rho\alpha \frac{fV|V|}{2D} = 0, \quad (10)$$

$$\frac{dx}{dt} = V - a. \quad (11)$$

**Finite-difference scheme.** For solving of the nonlinear equations (8) - (11) a finite difference method is used.

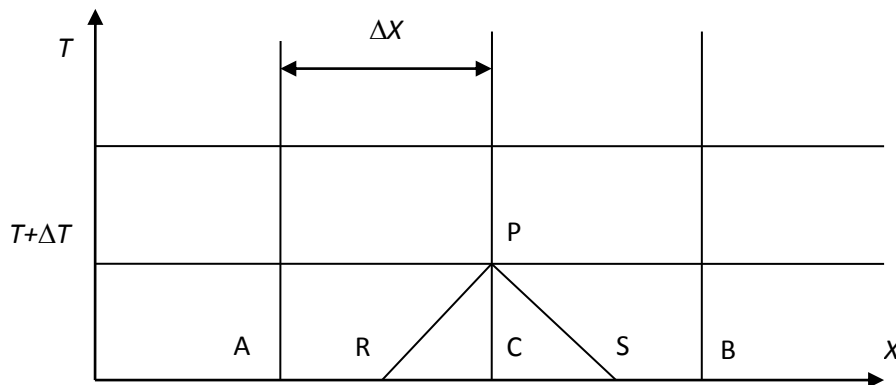

Fig. 1. Spatial - temporal grid

Spatial - temporal grid (Fig. 1) describes the state of the liquid at various points in the pipeline at time  $t$  and  $t + \Delta t$ . Pressure and velocity at points A, C and D, which correspond to time  $t$ , are known either from the previous step, or from data on the steady flow. States at R and S correspond to the time  $t$  and should be calculated from the values at points A, C and B. State at the point P corresponds to the time  $t + \Delta t$  is

determined from equations (8) - (11). Let us to write the equations (8) - (11) in finite differences and multiply it by an increment of time:

$$P_p - P_R + \rho a_R (V_p - V_R) - \rho a_R g \sin a (t_p - t_R) + \rho a_R \frac{f V_R |V_R|}{2D} (t_p - t_R) = 0, \quad (12)$$

$$(x_p - x_R) = (V_R + a_R)(t_p - t_R), \quad (13)$$

$$P_P - P_S + \rho a_S (V_S - V_S) - \rho a_S g \sin a (t_P - t_S) + \rho a_S \frac{f V_S |V_S|}{2D} (t_P - t_S) = 0, \quad (14)$$

$$(x_P - x_S) = (V_S + a_S)(t_P - t_S), \quad (15)$$

We have used a constant time step - a special time interval.

**Special time interval.** We will write the equations (12) and (14) as:

$$P_p = C_p - \rho a_R V_P \quad (16)$$

$$P_P = C_M + \rho a_S V_P \quad (17)$$

where

$$C_p = P_R + \rho a_R V_R \left( 1 + \frac{g}{V_R} \Delta t \sin a - \frac{f \Delta t |V_R|}{2D} \right) \quad (18)$$

$$C_M = P_S - \rho a_S V_S \left( 1 + \frac{g}{V_S} \Delta t \sin a - \frac{f \Delta t |V_S|}{2D} \right) \quad (19)$$

From Fig. 1 and (13):  $\frac{x_C - x_R}{x_C - x_A} = \frac{V_C - V_R}{V_C - V_A}$ , (20)  $\Rightarrow V_R = V_C - \frac{x_C - x_R}{x_C - x_A} (V_C - V_A)$

$$x_C - x_R = x_P - x_R = (V_R + a_R)(t_P - t_R)$$

We substitute this expression in (20):  $\frac{(V_R + a_R)(t_P - t_R)}{x_C - x_A} = \frac{V_C - V_R}{V_C - V_A}$ ,  $\Rightarrow$

$$\Rightarrow [V_R(t_P - t_R) + a_R(t_P - t_R)](V_C - V_A) = (V_C - V_R)(x_C - x_A),$$

$$V_R(t_P - t_R)(V_C - V_A) + a_R(t_P - t_R)(V_C - V_A) = V_C(x_C - x_A) - V_R(x_C - x_A),$$

$$V_R[(t_P - t_R)(V_C - V_A) + x_C - x_A] = V_C(x_C - x_A) - a_R(t_P - t_R)(V_C - V_A),$$

$$V_R = \frac{V_C(x_C - x_A) - a_R(t_P - t_R)(V_C - V_A)}{(t_P - t_R)(V_C - V_A) + x_C - x_A} \quad (*)$$

Divide (\*) by  $(x_C - x_A)$ , given that  $t_P - t_R = \Delta t$ ,  $x_C - x_A = \Delta x$ :

$$V_R = \frac{V_C - a_R \frac{\Delta t}{\Delta x} (V_C - V_A)}{1 + \frac{\Delta t}{\Delta x} (V_C - V_A)} = \frac{V_C - \xi_R (V_C - V_A)}{1 + \theta (V_C - V_A)} \quad (21)$$

$$\theta = \frac{\Delta t}{\Delta x} \quad (22)$$

$$\xi_R = a_R \frac{\Delta t}{\Delta x} = \theta a_R \quad (23)$$

Similarly, from Fig. 1 and (15) shows:

$$\frac{x_C - x_S}{x_C - x_B} = \frac{V_C - V_S}{V_C - V_B}, \quad x_C - x_S = x_P - x_S = (V_S + a_S)(t_P - t_S)$$

Combine these two expressions:  $\frac{(V_S + a_S)(t_P - t_S)}{x_C - x_B} = \frac{V_C - V_S}{V_C - V_B}, \Rightarrow$

$$\Rightarrow [V_S(t_P - t_S) - a_S(t_P - t_S)](V_C - V_B) = (V_C - V_S)(x_C - x_B),$$

$$V_S(t_P - t_S)(V_C - V_B) - a_S(t_P - t_S)(V_C - V_B) = V_C(x_C - x_B) - V_S(x_C - x_B),$$

$$V_S = \frac{V_C(x_C - x_B) + a_S(t_P - t_S)(V_C - V_A)}{(t_P - t_S)(V_C - V_B) + (x_C - x_B)} \quad (**)$$

Given that  $t_P - t_S = \Delta t, x_C - x_B = -\Delta x$  divide (\*\*) in  $(x_C - x_B)$

$$V_R = \frac{V_C \frac{x_C - x_B}{x_C - x_B} + a_S \frac{t_P - t_S}{x_C - x_B} (V_C - V_B)}{\frac{x_C - x_B}{x_C - x_B} + \frac{t_P - t_S}{x_C - x_B} (V_C - V_B)} = \frac{V_C - \xi_S (V_C - V_B)}{1 + \theta (V_C - V_B)} \quad (24)$$

Similarly,  $\frac{x_C - x_R}{x_C - x_A} = \frac{P_C - P_R}{P_C - P_A} \Rightarrow P_R = P_C - \frac{x_C - x_R}{x_C - x_A} (P_C - P_A) \quad (***)$

$$\frac{x_C - x_R}{x_C - x_A} = \frac{x_P - x_R}{x_C - x_A} \quad \text{from Fig. 1. Substitute in this expression (13)}$$

$$\frac{x_C - x_R}{x_C - x_A} = \frac{(V_R + a_R)(t_P - t_R)}{x_C - x_A} = (V_R + a_R) \frac{\Delta t}{\Delta x} + a_R \frac{\Delta t}{\Delta x} = V_R \theta_R + \xi_R.$$

Substituting this expression in (\*\*\*), obtain:  $P_R = P_C - (V_R \theta_R + \xi_R)(P_C - P_A) \quad (25)$

Similarly,  $\frac{x_C - x_S}{x_C - x_B} = \frac{P_C - P_S}{P_C - P_B} \Rightarrow P_S = P_C + \frac{x_C - x_S}{x_B - x_C} (P_C - P_B) \quad (***)$ ,

$$\frac{x_C - x_S}{x_B - x_C} = -\frac{x_C - x_S}{x_S - x_B} = -\frac{x_P - x_S}{x_C - x_B}. \quad \text{We substitute this expression in (15):}$$

$$\frac{x_C - x_S}{x_B - x_C} = -\frac{(V_S + a_S)(t_P - t_S)}{x_C - x_B} = (V_S - a_S) \frac{(t_P - t_S)}{x_B - x_C} = V_S \frac{\Delta t}{\Delta x} - a_S \frac{\Delta t}{\Delta x} = V_S \theta_S - \xi_S$$

We substitute this expression into (\*\*\*):  $P_S = P_C + (V_S \theta_S - \xi_S)(P_C - P_B) \quad (26)$

To save the convergence of these equations imply satisfaction with the Courant conditions:  $\xi \leq \frac{a}{V + a} \quad (27)$ . These conditions imply that in Fig. 1 points R and S are located between points A and B. Solving the equation (16) and (17) with the  $a_R = a_S$  we

get the pressure at point P:  $P_P = \frac{C_P + C_M}{2} \quad (28)$

To calculate the rate of  $V_P$  can be any of the equations (16) and (17). This completely determines the state at all interior points of the pipeline. Note the use of linear

interpolation of the pressure and velocity of the liquid in the pipeline. To maintain accuracy in the calculation of nonlinear systems, values  $\Theta$  and  $\xi$  must satisfy the Courant inequalities that involve interpolation only a small step of the grid.

Thus, the problem of flow in the pipeline is completely solved for interior points, but there remains the problem of establishing the boundary conditions at the endpoints, in which neither the  $C_P$  nor the  $C_M$  are uncertain.

At each end of the pipeline is only one of a pair of equations, i.e. equation (16) or (17). At the entrance to the pipeline is using the equation (17) and output from the pipeline - equation (16) (see Fig. 2).

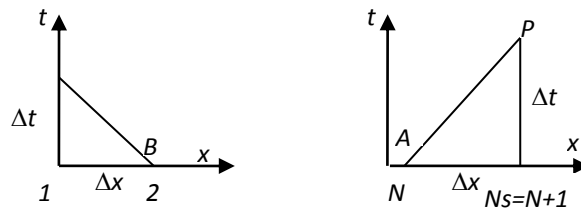

Fig. 2. Spatial-temporal grid for the boundary conditions at the constant cross section pipeline ends.

In order to determine the pressure and velocity at the ends of the pipeline, it is necessary to bring the auxiliary equations (boundary conditions), defined by the conditions at the ends of the pipeline.

If the pressure at the inlet or outlet of the pipeline is a known function of time  $F(t)$ , then this relation can be combined with equation (16) or (17) to determine the status of a boundary point.

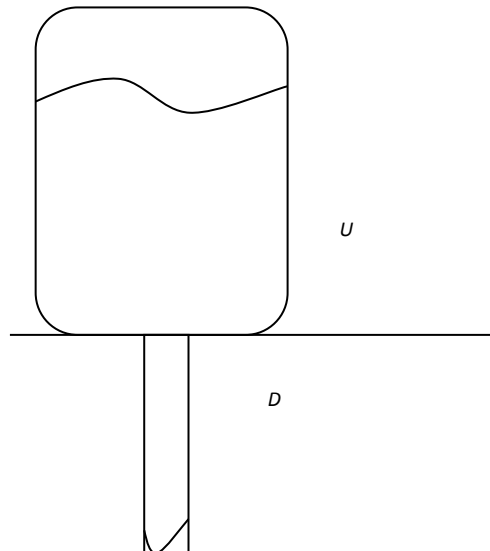

Fig. 3. Diagram illustrating the change in the cross section of the pipe.

A known pressure at the inlet to the pipeline:

$$P_U = F(t), P_D = P_U, P_D = C_M + \rho a_D V_D \Rightarrow V_D = \frac{F(t) - C_M}{\rho a_D} \quad (29)$$

A known pressure at the outlet of the pipeline:

$$P_D = F(t), P_U = P_D, P_U = C_P + \rho a_U V_U \Rightarrow V_U = \frac{C_P - F(t)}{\rho a_U} \quad (30)$$

The expression of continuity for incompressible fluid  $A_U V_U = A_D V_D$  (31),

Where  $A_U, A_D$  - cross-sectional area of pipelines.

Assuming the absence of energy dissipation (i.e., the absence of losses) at the interface of pipelines and equating the full of pressure on each side of the junction, we obtain:

$$P_U = C_P - \rho a_U V_U, \quad P_D = C_M - \rho a_D V_D, \quad P_U + \frac{1}{2} \rho V_U^2 = P_D + \frac{1}{2} \rho V_D^2, \\ \frac{1}{2} \rho V_D^2 + C_M + \rho a_D V_D - \frac{1}{2} \rho V_U^2 - C_P + \rho a_U V_U = 0, \quad (32)$$

$$\frac{1}{2} \rho V_D^2 + C_M + \rho a_D V_D - \frac{1}{2} \rho \left( \frac{A_D}{A_U} \right)^2 V_D^2 + C_P + \rho a_U \frac{A_D}{A_U} V_D = 0,$$

$$V_D^2 (1 - \beta^2) + 2(a_D + \beta a_U) V_D + \frac{2}{\rho} (C_M - C_P) = 0$$

$$\text{Or } A \cdot V_D^2 + B \cdot V_D + C = 0, \quad (33)$$

where  $\beta = \frac{A_D}{A_U}$

To obtain a positive rate of flow is necessary to use the positive square root of the formula:

$$V_D = \frac{-B + \sqrt{B^2 - 4AC}}{2A} \quad (34)$$

Substituting (34) into the (31), (16), (17) we obtain all the necessary quantities at the interface of the pipelines.

The only assumption made was the neglect of energy dissipation at the junction. This assumption is quite reasonable for the case of relatively low velocity of fluid flow in the piping systems under consideration, as well as for the piping systems with a streamlined shape.

The equation of flow through the diaphragm has the form:

$$V_D = \tau \sqrt{P_D - P_U}, \quad P_U = C_P - \rho a_U V_U, \quad P_D = C_M + \rho a_D V_D, \quad A_U V_U = A_D V_D, \quad (35)$$

Where  $V_D$  determined from the quadratic **equation** with coefficients

$$A = 1, \quad B = \tau^2 \rho (\beta a_U + a_D), \quad c = \tau^2 (C_M - C_P)$$

Other unknowns are easily found from (31), (16), (17).



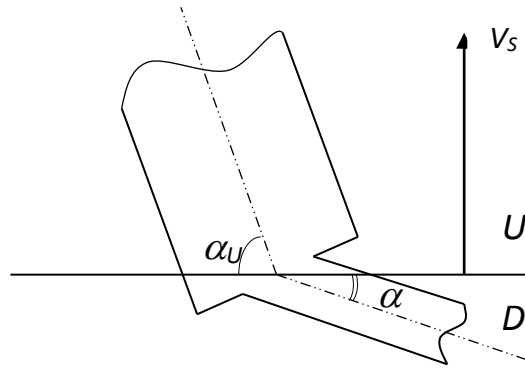

Fig. 4. The joints scheme of various sections of pipelines.

Fig. 4 shows the relative motion between the two elements of the system. If the size and orientation of the two elements are not identical, in general, in the place of joining of these elements will be some accumulation or exudation of liquid associated with a relative displacement of elements.

Equating the rate of accumulation of fluid flowing, and the difference between the expenditure of the effluent, we obtain:

$$A_U V_U - A_D V_D = -V_S (A_U \sin \alpha_U - A_D \sin \alpha_D) \quad (36)$$

If we assume that the velocity of the design section  $V_S$  directed vertically, while the fluid velocity  $V_U$  and  $V_D$  directed along the axis of the pipe, oriented at an angle  $\alpha_U$  and  $\alpha_D$ , from the equations (16) and (17)

$$P_U = P_D, V_U = \beta V_D - V_S (\sin \alpha_U - \beta \sin \alpha_D) \quad (37)$$

The action of the pump can be approximated by the pressure jump in the value of  $\Delta P$ , if the size of the pump is small in comparison with other elements of the system. The boundary conditions in this case would be the same as in the case when the pressure is known:

$$P_U = C_P - \rho \alpha_U V_U, P_D = C_M + \rho \alpha_D V_D, P_D = P_U + \Delta P, A_U V_U = A_D V_D, \\ C_M + \rho \alpha_D V_D = C_P - \rho \alpha_U \beta V_D + \Delta P \Rightarrow V_D = \frac{C_P - C_M + \Delta P}{\rho (\alpha_D + \beta \alpha_U)} \quad (38)$$

The damper is a concentrated yielding at a docking site of two elements.

Since the damper is a pressure accumulator (total energy and the amount of liquid in it are the function of pressure), the change in pressure in it is described by a differential equation. Yielding of the damper is given by:  $b' = \frac{dVol}{dP}$  (39)

As in the case of relative motion, the rate of accumulation of fluid in the damper is equal to the difference between the inlet and outlet pressure:

$$V_U A_U - V_D A_D = \frac{dVol}{dt} = \frac{dVol}{dP} \frac{dP}{dt} = b' \frac{dP_U}{dt}, \frac{dP_U}{dt} = \frac{V_U A_U - V_D A_D}{b'} \quad (40)$$

**The results of the calculations.** Implementation of this mathematical model to that shown in Fig. 5 a long pipeline diagrams was carried out by creation and debugging a software using a complex algorithm as an operation and interaction of software modules.

Since one of the problems was the task of creating the comprehensive software with its user-friendly graphical user interface (GUI), it was decided to carry out a set of numerical values of the original data through pop-up windows, which contains the information about the current input parameters with all the necessary explanations and tips. See Fig 6.

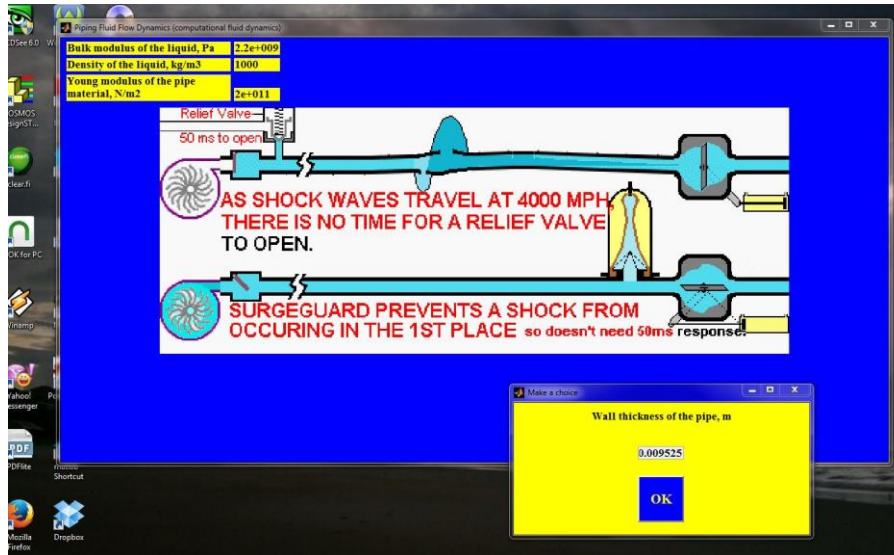

Fig. 5. GUI look at the dataset.

Fig. 6 shows the GUI while setting the next value of the current parameter.

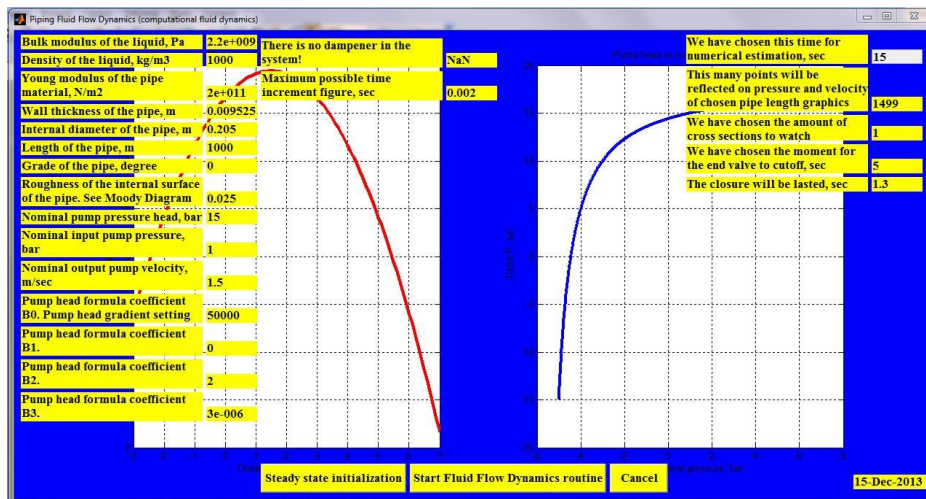

Fig. 6. GUI look at the computation procedure. In the boxes the numerical values of the system parameters for which the current calculation is conducting are displaying.

Following are the results of the trial calculations for water pipe length of 3000 m, with a wall thickness of 9.525mm steel and an inner diameter of 205 mm. Rated pump head 15bar at nominal input pressure of 1 bar and a nominal flow rate at the outlet of the pump 1.5m/s (at a steady flow). The mass flow rate of the working fluid was 27.8 kg/sec (at a steady flow). At the end of the pipe before the valve was

installed damper. The flap at the end of the pipeline began to close on 5 second. Response time to complete closure flap is 1.3 seconds.

Figs. 7, 8 and 9 show the graphs of changes in the instantaneous pressure and the particle velocity of the working fluid (water in this calculation) in the nodal point section of spatio-temporal grid nearest to the throttle duct for the three variants of the dampener parameters which is installed at the end of the pipeline.

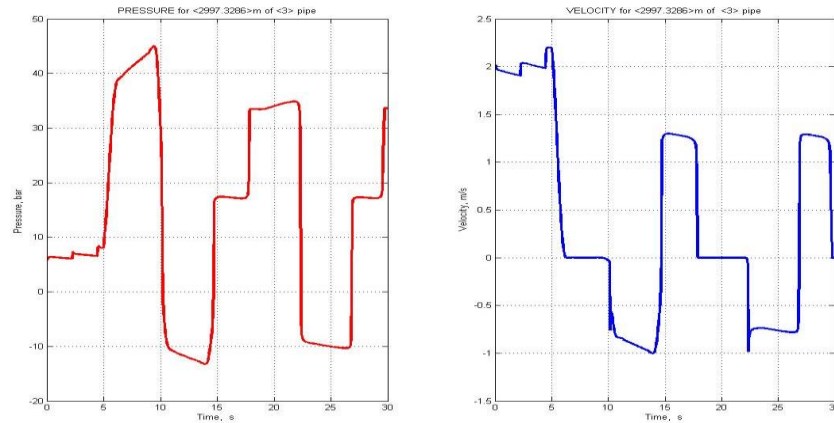

Fig. 7. Figure of instantaneous changes in pressure and particle velocity of the working fluid in the selected section of the pipeline. The pressure and volume of the dampener gas cushion is 20bar and 5 liters, respectively.

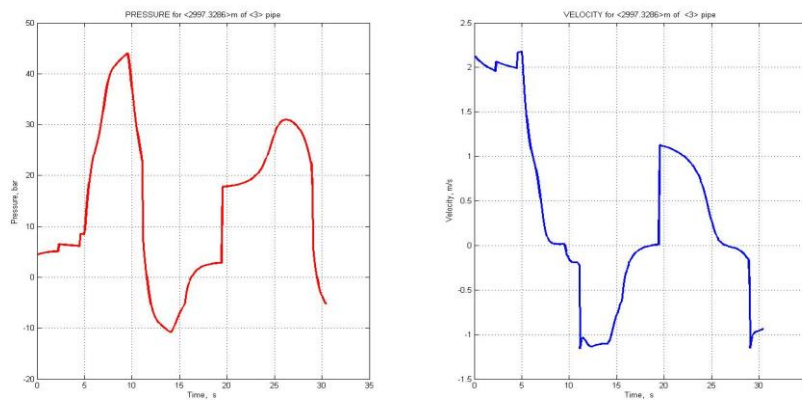

Fig. 8. Figure instantaneous changes in pressure and particle velocity of the working fluid in the selected section of the pipeline. The pressure and volume of a gas cushion is 20 bar and 50 liters, respectively.

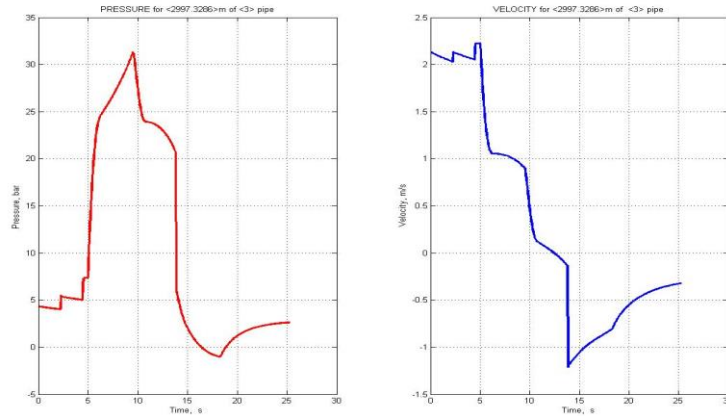

Fig. 9. Figure instantaneous changes in pressure and particle velocity of the working fluid in the selected section of the pipeline. Pressure and volume of a gas cushion is 20 bar and 250 liters, respectively.

As can be seen from Figs. 7, 8 and 9 graphs, obtained for the pump and piping configurations for different values of the volume of the gas cushion damping device, when sequentially building a gas cushion volume 5Lt, 50Lt, 250Lt, respectively the oscillation frequency of the working fluid with the elastic part of the steel pipe wall varies from 0.1 Hz through 0,067 Hz and at the value of the gas cushion 250Lt the flow after starting the unit spike of pressure, goes to be "aligned" in close to steady flow since 25 seconds. It can be concluded that at a pressure of a gas cushion equal to 20 bar, the volume of gas cavity damper should be used 250Lt to "smooth" flow in the pipeline and almost complete suppression of the hydraulic impact phenomena spread in a liquid medium for a given parameters combination such a long pipeline.

**Outcome.** As a result of the completed research the familiarization with the methods of mathematical modeling of hydro-mechanical processes was implemented by using the method of characteristics applied to the modified nonlinear Navier-Stokes differential equations.

The proposed approach for the numerical integration of the Navier-Stokes equations on the spatio-temporal grid by the method of characteristics had allowed to input practical computing parameters of the working fluid in long pipelines, with taking into account the boundary conditions for the butt section of the pipeline, which determine the behavior of pumps, diaphragm valves, dampener devices connected to these sections.

The mathematical model for predicting of the peak pressure amplitudes caused by various inhibitory factors that lead to the return of the mass flow, and then with its use, program computer's complex were developed and debugged. For easier use of the program complex was created a graphical users interface. The program is finished to working condition and has been used as simulation software for the test workstation based on the PC with using the operating systems Windows 10.

Implemented calculations have been showing the complete fitness of the results of these developments for the solution the main challenge goal of the project by cor-

rect chosen parameters of the alleviation dampener to get proper and smooth fluid flow in the pumped industrial pipelines and suppress the hydropercussion (water - hummer) phenomena. The water hummer effect has been numerically simulated by sudden overlap of flow section of the pipeline and the suppress of the arised pressure head was numerically simulated by using the dampener mounted to the distal end of the pipeline.

#### REFERENCES

1. Dorsch, Robert G., Wood, Don J., Lightner, Charlene. (1966) *Distributed parameters analysis of pressure and flow disturbances in rocket propellant feed systems*: - NASA Technical Note. Washington DC, – 54с.
2. MATLAB Compiler, (2002) *The Language of Technical Computing*: Sixth printing, Revised for Version 3.0, The MathWorks, Natick, MA. 274с.
3. Bakar, R. A., Firoz, T. *Simulation of transient flows in a hydraulic system with a long liquid line*. American Journal of Applied Sciences 2 (5): 1003-1007, ISSN 1546-9239, 5.
4. Chaudhry, M. H., Hussaini, M. Y., (1985), *Second-order explicit finite-difference schemes for waterhammer analysis*, Journal of Fluids Engineering, 107, 523-529.
5. Wylie, E. B., Streeter, V. L., (1978), *Fluid Transients*, McGraw-Hill, New York.
6. Лисанов, М. В., Сумской, С. И., Софьин, А.С., и др.. (2015) *Моделирование гидроудара в разветвленных трубопроводных системах*, Ж-л «Безопасность Труда в Промышленности» № 10. 2015. Москва: НИЯУ МИФИ, ЗАО НТЦ ПБ, РХТУ им. Д.И. Менделеева. С. 60-66.
7. Ludecke, Horst-Joachim, Kote, Berndt, Pauly, Christoph (2015) *Surge: causes, analysis and prevention methods* / Water supply and sanitary technique. 2015. No. 8. Germany.

#### АННОТАЦИЯ

**Цель.** Разработка математической модели гидромеханического переходного процесса в потоке рабочей жидкости системы промышленного трубопровода, содержащей насос и демпфер, с учетом жесткости и шероховатости его стенок в момент имитации резкой остановки этого потока путем закрытия заслонки на его отдаленном конце, при дальнейшем внедрении этой модели для использования в виде программногo комплекса с использованием учебной версии системы программирования пакета Matlab.

**Методика исследований.** Расчет переходных процессов и частотных характеристик участка трубопровода большой длины, в систему котрого включено роторный насос и демпфер, построен на базе нелинейной математической модели модифицированный уравнений Навье-Стокса. Эффект быстрого перекрытия потока достигался с использованием математического экспоненциального закона уменьшения площади поперечного сечения трубопровода, что позволило промоделировать работу промышленных заслонок.

Основой численного моделирования являлся метод характеристик, который применялся для решения указанной системы уравнений Навье-Стокса. Полученные в результате таких преобразований нелинейные дифференциальные уравнения численно интегрировались при помощи метода конечных разностей первого рода.

**Результаты исследований.** Разработана математическая модель для прогнозирования пиковых амплитуд давления, обусловленными различными тормозящими причинами, приводящими к возвратному массовому потоку и, с ее использованием, программный вычислительный комплекс, который использован в качестве моделирующего программного обеспечения на основе персонального компьютера, использующего ОС Windows Vista и Windows 7, 10.

**Научная новизна.** Предложенные подходы для численного интегрирования системы уравнений Навье-Стокса на пространственно-временной сетке методом характеристик позволили перейти к непосредственным вычислениям параметров течения рабочих жидкостей в длинных трубопроводах, с учетом граничных условий для стыковых сечений трубопроводов, которые определяют поведение насосов, диафрагм, заслонок, демпферных устройств, подключаемых к указанным сечениям.

**Практическое значение.** Проведенные расчеты показали полную пригодность результатов данных разработок для решения задачи выбора приемлемых параметров демпфирующего устройства для подавления гидроударных явлений, возникающих при имитации внезапного перекрытия проходного сечения трубопровода при помощи заслонки, устанавливаемой на удаленном конце трубопровода.

**Ключевые слова:** *промышленный трубопровод, демпфер, программное обеспечение (ПО), вычислительная гидродинамика (CFD), операционная система (ОС), переходной процесс, метод характеристик, компьютер (ПК), графический пользовательский интерфейс.*

### ABSTRACT

**Purpose.** The mathematical model development of the working fluid flow hydromechanical transient at an industrial pipeline system containing a pump and a damper, taking into account the inflexibility and roughness of its walls at the time of simulating a sudden stop of this flow by closing the valve at its remote end, with the model implementation for further use as a software program complex on the Matlab system light version basis.

**The methodology.** The transient processes and frequency characteristics numerical modeling of a long-length pipeline section fluid flow, with a rotary pump and a damper included, had been built by the nonlinear mathematical model of the modified Navier-Stokes equations basis. The effect of rapid flow overlap was achieved by using the mathematical exponential law of reducing the pipeline cross-sectional area, which allowed to simulate the operation of industrial valves.

The basis of the numerical simulation was the method of characteristics, which was used to solve the specified Navier-Stokes equation system. The nonlinear differential equations obtained as a result of such transformations were numerically integrated by using the finite-difference method of the first grade.

**Findings.** A mathematical model for the pressure peak amplitudes predicting due to the various retarding reasons leading to a recurrent mass flow and, with its use, a software computational complex that is used as modeling software based on a personal computer under the OS Windows Vista, Windows 7, 10 has been developed.

**The originality.** The proposed approaches for the Navier-Stokes equations system numerical integration on the spatial - temporal grid by the method of characteristics made it possible to proceed to direct calculations of the flow parameters of working fluids in long pipelines, taking into account the boundary conditions for the pipe butt joints that determine the behavior of pumps, diaphragms, dampers, connected to the specified cross-sections.

**Practical implications.** The performed calculations showed the complete suitability of these developments results for the acceptable parameters choosing problem resolving of the proper damping device for suppressing hydrostatic phenomena that occur when simulating the pipeline cross-section sudden overlap by the valve installed at the remote end of the pipeline.

**Keywords:** *industrial pipeline, dampener, software, Computational Fluid Dynamics (CFD), operating system (OS), transient process, method of characteristics, computer (PC), graphical user interface (GUI).*