

SECONDARY OPENING OF PRODUCTIVE LAYERS BY MECHANICAL DEVICES

Dnipro University of Technology

Zotov Vladyslav Serhiyovych

Supervisor: Doctor tech. science, Bondarenko Mykola Oleksandrovych

When using mechanical perforators, the destruction of the cement ring is excluded and, accordingly, the tightness of the sealed space is preserved, rock compaction and contamination of the walls of the perforation channels with explosion products is excluded. The productivity of the well increases, up to a multiple, and the ecological cleanliness of the perforation process is ensured. The most preferred use of mechanical perforation in the development of low-power oil-saturated intervals, which for one reason or another were not used at the initial stage of field exploitation, i.e. when:

- small thickness (up to several meters) of productive layers or interlayers;
- low permeability of collectors;
- proximity of water-oil contact, absorbing intervals and in a number of other cases.

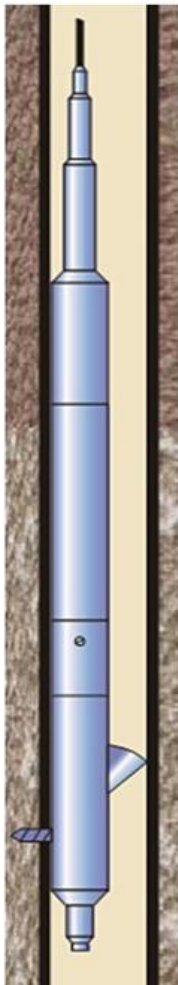

Fig. 1. Drilling perforator
1 – cable-rope; 2 – body;
3 – deflector; 4 – drill

The perforators are driven by a hammer electric or screw hydraulic motor. The advantage of the electric drive is the higher manufacturability of the process (descent into the well on a cable), the disadvantage is the limitation of applicability in terms of engine power and well depth, the difficulty of deep perforation (up to 1-7 m) with additional use, for example, of a hollow (for washing the drill) flexible shaft.

The drilling perforator is shown in fig. (1). Its electric drive is combined with a diamond drill. The maximum radial movement of the drill is 60 mm, which ensures the passage of the casing string, cement ring and entering the formation to a depth of no more than 20 mm.

Features and benefits:

- forms perforating channels without impact on the elements of fastening wells;
- creates holes of large diameter with a clean edge;
- has a high selectivity when opening thin-layered layers;
- provides effective dissection of low-power formations with bottom water and oil and gas-bearing objects separated by a thin, unstable bridge.

Allows to increase the efficiency of secondary dissection by drilling:

- carbonate collectors with deteriorated filtration properties;

- productive objects with a deep zone of PZP clogging;
- zones with an eccentric arrangement of casing pipes, cavernous sections of the trunk, inclined wells and sections of the trunk prone to guttering.

The perforator can be used in wells lined with pipes with a diameter of 140-168 mm, designed for operation with a logging laboratory and a hoist equipped with a three-wire cable up to 4500 m long.

To solve the problem of deep penetration of perforation channels into the productive layer, a new generation drilling perforator PS-500 with a drill output of up to 500 mm and a perforation channel diameter of 20 mm was developed (Fig. 2).

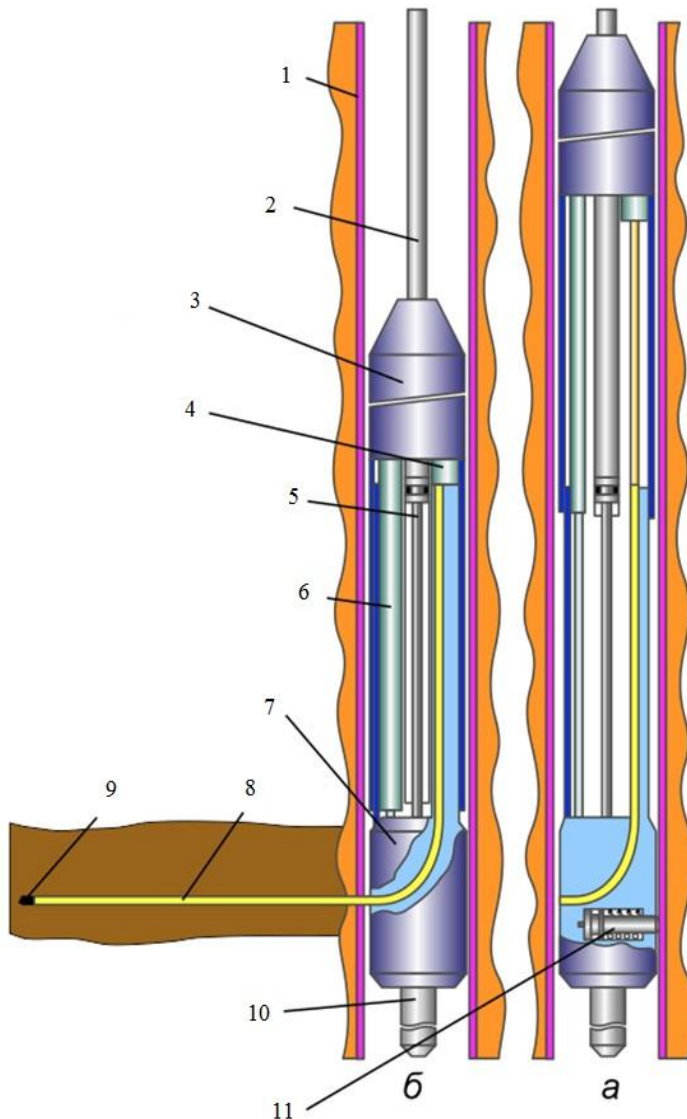

Fig. 2. Drilling perforator PS-500:

- a – in the process of loosening in the well; b – in the process of work:
- 1 – well; 2 – cable; 3 – drive; 4 – flushing pump;
 - 5 – drill feeding system; 6 – drill output control sensor; 7 – deflector; 8 – flexible shaft; 9 – drill;
 - 10 – return system; 11 – perforator pressing system

The perforator is designed for carrying out work in wells of various purposes lined with an operational column with a diameter of 146-168 mm. The perforator makes it possible to create perforation channels of deep penetration, connecting the wellbore with an undisturbed zone of the formation that has natural filtering properties without destroying the integrity of the wellbore attachment and without violating the natural drainage properties of the productive formation. In complex geological and technological conditions, when low-power formations with bottom water are involved in operation and objects where the oil-saturated part of the formation is separated from the water-saturated part by a thin, unstable bridge, the deep penetration drilling perforation technology has no alternative. A good effect should be expected when drilling perforation is applied as a method of intensification, when pre-perforating long-term exploited, heavily clogged layers.

The perforator is a complex of electromechanical and hydraulic systems and assemblies that ensure fixing the perforator in

the well, drilling deep perforation channels in the wall of the well and the productive

collector, and further returning the mechanisms of the perforator to the transport (initial) position.

The perforator includes a drive module that adds axial feed and rotational load to the flexible shaft with a cutting tool, a pressing module that fixes the perforator in the well, a flexible deflector assembly that transfers the flexible shaft from the axial direction to a radial direction, a flexible shaft with a cutting tool at the end, a washer a system that washes the perforation channel from chips and mud during the drilling process, a mechanism for returning the flexible shaft with the cutting tool to its initial position.

The control panel is designed to control the device from the surface of the well and control the drilling process. Control over the process is carried out by the load current of the motor and by the information received from the sensor of the movement of the drill. All parameters of the drilling process are recorded on the computer. The presence of an electronic drill force control unit allows the operator to comfortably control the operation of the device. The system of emergency devices makes the perforation process safe.

Before lowering the device into the well, the device is checked for operability on the rig bridges. Then the device on the logging cable is lowered into the intended perforation interval. The pressing module fixes the device in the wellbore, the drive module creates an axial feed force and transmits the rotational force to a flexible shaft with a cutting tool at the end. The flexible shaft, according to the flexible deflector system, converts the axial movement of the cutting tool into radial movement. The cutting tool, going beyond the body of the device, drills the wall of the well, cement stone and rock, creating a perforation channel with a diameter of 20 mm and a length of up to 500 mm. The return assembly then returns the cutting tool to its initial position. The clamping unit returns to the transport state. The device moves to the next drilling point.

Research has established that there is a dense layer at least 15-50 cm thick in the pre-fracturing zone of the formation, which was formed as a result of clogging of the near-well zone of the formation with particles of drilling fluid and plugging mixture during the process of drilling the well and hardening of the cement ring in the backspace.

Drill perforation with PS-112 perforators is not able to overcome the occlusion layer. Cumulative perforation is also unable to overcome this layer.

The only way to successfully overcome this layer is drilling perforation with an increased (up to 500 mm) output of the drilling tool.

References

1. Pashchenko O., Korovyaka E., Khomenko V. Determination of drilling technological modes. Proceedings of the International Conference on Integrated Innovative Development of Zarafshan Region: Achievements, Challenges and Prospects (27-28 October, 2022. Navoi, Uzbekistan). Volume I. – 191-194 pp. http://idz.ndki.uz/wp-content/uploads/2022/11/Volume-I_compressed.pdf.