

**CIRCULAR ECONOMY PRINCIPLES IN MODELING AND  
PRODUCTION OF THE “CYLINDER” PART MACHINING**

Lappeenranta–Lahti University of Technology LUT

Master’s in ENTER Program, Master's thesis

2022

Nikita Saranov

Examiner(s): Professor Antti Häkkinen

Professor Henning Zeidler

Ph.D., Associate Professor Vitaliy Derbaba

## Master's thesis

for the Joint Study Programme

**“International Master of Science in Engineering, Entrepreneurship and Resources”**  
(MSc. ENTER)

**TOPIC:** Circular economy principles in modelling and production of the “Cylinder” part machining

edited by: Saranov Nikita

for the purpose of obtaining one academic degree (triple degree) with three diploma certificates

Supervisor / scientific member (HU): Ph.D., Associate Professor Vitaliy Derbaba

Supervisor / scientific member (LUT): Professor Antti Häkkinen

Supervisor / scientific member (TU BAF): Professor Henning Zeidler

Handover of the topic: 03.05.2022

Deadline of the master's thesis: 12.12.2022

Place, date: ...Dnipro, 09.12.2022.....

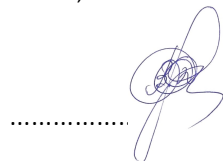

.....  
Ph.D., As. Pr. Vitaliy Derbaba

Supervisor / member HU



.....  
Professor Antti Häkkinen

Supervisor / member LUT

.....

Professor Henning Zeidler

Supervisor / member TU BAF

Supported by



This activity has received funding from the European Institute of Innovation and Technology (EIT), a body of the European Union, under the Horizon 2020, the EU Framework Programme for Research and Innovation



## Statement of Originality

I hereby certify that I am the sole author of this thesis and that no part of this thesis has been published or submitted for publication.

I certify that, to the best of my knowledge, my thesis does not infringe upon anyone's copyright nor violate any proprietary rights and that any ideas, techniques, quotations, or any other material from the work of other people included in my thesis, published or otherwise, are fully acknowledged in accordance with standard referencing practices.

Place, date: .....Dnipro, 09.12.2022.....

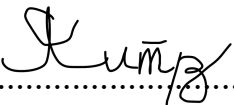
  
.....  
Signature of the student

## ABSTRACT

Lappeenranta–Lahti University of Technology LUT

LUT School of Engineering Science

Chemical Engineering

Nikita Saranov

### **Circular economy principles in modelling and production of the “Cylinder” part machining**

Master’s thesis

2022

95 pages, 20 figures, 14 tables, 2 appendices

Examiner(s): Professor Antti Häkkinen, Professor Henning Zeidler, Ph.D. Associate Professor Vitaliy Derbaba

Keywords: blank, technological process, milling, drilling, threading, CAD / CAM systems, CNC machine, cutting tool, cylinder, environment, remelting, life cycle, waste.

Machining a part by milling on modern CNC machines is one of the best ways to get surfaces with accurate dimensions and the part with high surface accuracy.

This thesis examines the process of machining of a "Cylinder" part in the CAM-environment Autodesk FeatureCAM 2019.

The target of this research was the optimization of the machining process using the CAM-system Autodesk FeatureCAM 2019, which has the ability to control and edit the machining process in many axis CNC machines.

The purpose of the thesis is to determine and obtain optimal trajectories of milling and drilling in a multifunctional unit with CNC for optimization in production. Were considered possibilities of utilization production waste and parts after the end of its life cycle. Search for alternative types of materials for the manufacturing of the "Cylinder" part and determination the features of remelting titanium alloys were performed. Activities to protect the environment, air and water at the enterprise from pollution were studied.

Research methodology used in this study was computer simulation of cutting, milling and drilling operations in the environment of the CAM program, namely Autodesk FeatureCAM 2019.

The result is the finding of the optimal trajectory of machining parts. This means obtaining the parameters for the most optimal and fastest machining of the "Cylinder" part. Also, obsolete cutting tools were replaced with modern, progressive and effective in modern production.

The scientific novelty of the qualification work is the rational method of manufacturing the "Cylinder" part in the automated mode under the conditions of using CAD \ CAM systems on multi-purpose CNC machines.

The practical value lies in the development of guidelines for the rational technology of machining parts, the choice of advanced cutting tools, equipment and hardware with software control.

# CONTENT

INTRODUCTION.....	3
1 ANALYTICAL SECTION .....	6
1.1 Feasibility study of project input data.....	6
1.2.1 Cylinder manufacturability analysis .....	7
1.3 Determination of the production program of the workshop .....	7
1.4 Determining the type of production.....	11
1.5 Analysis of technological processes of the base plant.....	13
1.5.1 Routing process of the base cylinder processing plant.....	13
1.5.2 Suggestions for improving factory processes .....	15
2 TECHNOLOGICAL SECTION.....	16
2.1 Process design .....	16
2.1.1 Selecting a method for obtaining blanks.....	16
2.2 Determination of the sequence of technological operations and the choice of equipment.....	19
2.2.1 Determining the sequence of technological operations .....	19
2.2.2 Rationale for accepted equipment.....	20
2.3 Selection and justification of technological and measuring bases.....	24
2.4 Design of the operational process .....	25
2.5 Selection of fixtures, cutting tools and engineering controls .....	26
2.5.1 Selection of fixtures and auxiliary tools .....	26
2.5.2 Choosing ISO cutting tools.....	26
2.5.3 Selection of engineering controls.....	27
2.6 Selection and calculation of processing modes .....	28
3. SPECIAL SECTION.....	30
3.1 Choice of technological equipment .....	30
3.1.1 Analysis of source data .....	30
3.1.2 Force calculation fixture .....	32
3.1.3 Evaluation of fixture accuracy .....	38
3.2 ISO cutting tool.....	40
3.3 Machine tools and clamping devices .....	43
3.4 Measuring tools.....	45
3.5 Creating control program in Autodesk FeatureCAM software .....	47
4 SCIENTIFIC SECTION .....	53
4.1 Circular economy. Disposal of industrial waste .....	53
4.2 Lubricants and coolants .....	55
4.3 Part life cycle.....	64
4.3.1 Product recycling .....	66
4.3.2 Features of melting titanium alloys.....	70
4.4 Alternative materials for part production.....	74
4.4.1 Prospects and problems of using titanium alloys.....	76
4.4.2 Equipment for processing titanium alloys .....	78
4.5 Environmental protection.....	81

4.5.1 Overview of environmental protection activities in enterprises associated with the processing and operation of metal products.....	81
4.5.2 Protection of the air and water basin at the enterprise from pollution...	83
4.6 Disposal of metal waste .....	87
4.6.2 Mitigation of environmental impact. ....	89
4.6.3 Reducing the environmental footprint .....	90
CONCLUSIONS AND SUGGESTIONS FOR THE PROJECT .....	92
REFERENCES .....	94

APPENDIX A Technological process of manufacturing the "Cylinder" part.

APPENDIX B Drawings and sketches of the part

## INTRODUCTION

Technological progress is a continuous process of discovering new opportunities and applying them in engineering production, allowing to combine available resources in a new way in order to increase the production of high-quality end products at the lowest cost. In a broad sense, at any level - from the production site to the enterprise as a whole - the technological process means the creation and implementation of new equipment, technology, materials, the use of new energy types, as well as the emergence of previously unknown methods of organizing and managing production.

The introduction of new technology is a very complex and controversial process. It is generally accepted that the improvement of technical means reduces labor costs, the part of labor in the cost of a unit of output product. However, at present, technical progress is "rising in price", since it requires the creation and use of more and more expensive machine tools, lines, robots, computer control facilities; increased spending on environmental protection. All this is reflected in the increase in the share of costs for depreciation and maintenance of the fixed assets used in the cost of production. However, the competitiveness of the enterprise, their ability to stay in the market of goods and services depends, first of all, on the susceptibility of manufacturers of goods to the latest equipment and technology, which allows to ensure the production and sale of high-quality goods with the most efficient use of material resources.

Therefore, when choosing options for equipment and technology, we must clearly understand what strategic or tactical tasks the equipment is intended to solve.

Properly designed technological processes for manufacturing products, monitoring the quality and quantity of products, checking performance, timely implementation of appropriate work to eliminate emerging defects and creating normal operating conditions - all these are measures that increase the durability of products and their reliability.

The main directions in the design of technological processes are:

- improving the quality characteristics of materials, stabilizing and reducing the volume of their consumption through the use of advanced methods for obtaining blanks;
- ensuring the maximum possible continuity, safety, flexibility and productivity of the technological process, which can be ensured as a result of improving the level of mechanization and automation;
- increasing the level of completeness of process mechanization through the use of modern equipment: CNC machines, automatic and semi-automatic machines, the use of high-performance types of technological equipment, in order to reduce the labor intensity of manufacturing parts and products as a whole.
- improvement of control and testing works and rational organization of production.

These measures allow, at a relatively low cost, to significantly increase the quantity and range of products, improve its quality.

The improvement of the technological process of processing products should lead to an increase in the quality of the product, a decrease in the cost of production, etc.

The development of the economy in the country is possible only with the implementation of high-tech and resource-saving production, capable of quickly developing and implementing competitive new generation products focused on meeting the needs of domestic and foreign markets.

In market conditions, production must quickly respond to changing requirements, and this requires the use of the latest technologies that can reduce the development time, mastering the production and entering the market of a new product. Within the framework of integrated technologies, these tasks are successfully solved.

The purpose of this work is an effective technology for automated production of parts in batches, through the use of modern CAD - CAM systems, high-precision equipment, advanced cutting tools and machine tools with numerical control. This

project will allow preparing production for accelerated shaping and manufacturing of a part that is part of the landing gear assembly of the AN 148 aircraft.

# **1 ANALYTICAL SECTION**

## **1.1 Feasibility study of project input data**

The initial data for the development of technological processes is the drawing of the cylinder assembly 148.004111.000.000, the working drawing of the cylinder 148.004111.303.000, the technical requirements for the product, the graduation program and other materials of undergraduate practice.

### **1.1.1 Service purpose of the product**

The “cylinder” part under consideration is included in the shock absorber assembly of the landing gear of the AN 148 aircraft. The landing gear provides absorption loads during landing and the movement of the aircraft on the ground, and also allows you to control taxiing and braking when the aircraft is moving on the ground. A shock absorber is a device that converts mechanical energy into thermal energy. It serves to dampen vibrations (damping) and absorb shocks and shocks acting on the body (frame). Its task (as well as the task of the entire chassis design) is similar to shock absorbers in cars - to mitigate overloads in contact with the runway coating during landing, so that the loads on the aircraft nodes do not exceed the allowable during a normal landing, and also so that in emergency cases make a safe landing for people when exceeding the maximum landing weight up to the maximum takeoff weight.

Therefore, strict requirements are imposed on this node. First of all, this is rigidity, high strength and, along with this, lightness, because excess weight has a detrimental effect on the flight characteristics of the aircraft. This is excessive fuel consumption, which is very important, since efficiency is one of the main conditions for modern aircraft.

## **1.2 Analysis of the manufacturability of the part**

The analysis of the manufacturability of the design of the part is reduced to the study of the possibilities of reducing the labor intensity and material consumption, reducing the cost, processing it with high-performance methods

without compromising the official purpose and maintainability. The manufacturability of the design largely depends on the scale of production and the type of production.

Manufacturability is determined by the degree of compliance of the design of the part with the conditions of its manufacture. ISO 9001:2015 provides for a qualitative and quantitative assessment of the manufacturability of a design.

### **1.2.1 Cylinder manufacturability analysis**

Structurally, the part belongs to the class "Hollow cylinders". The cylinder is made of titanium alloy of high strength VT22.

The main technological tasks in the manufacture of a cylinder are to achieve concentricity of the inner and outer surfaces and perpendicularity of the ends to the axis. These tasks are solved by processing the hole first, and then the outer surface when installing the part along the hole.

The configuration of the part provides free access for cutting and measuring tools. The configuration has sufficient rigidity ( $l/d < 12 = 530/146 < 12$ ).

The dimensions on the drawing are correct, complete and convenient for control. The surface roughness corresponds to the processing precision.

In general, the detail is technological.

### **1.3 Determination of the production program of the workshop**

This machine shop of small-scale production type will be designed according to the above program. In this case, a representative part is selected, and all other parts included in the program are conditionally given in terms of labor intensity, complexity and weight to the representative product.

The given production program is defined as follows. We bring all the variety of details to several characteristic representatives, since some of the details are not fully provided with drawings and other initial data. In this case, the entire range is divided into several groups, each of which includes products of the same type in design and technology. In each group, a representative product is allocated, to which all other parts of this group lead.

The calculation of the given annual program of the machine shop is carried out according to the formulas [1].

General reduction factor:

$$K = K_w \cdot K_{ser.} \cdot K_{com.} \quad (1.1)$$

where  $K_w$  – weight reduction coefficient;

$K_{ser.}$  - serial reduction coefficient;

$K_{com.}$  - reduction factor by complexity;

$K_{com.}=1/$

$$K_w = \sqrt[3]{\left(\frac{m_x}{m}\right)^2} \quad (1.2)$$

where  $m_x$ ;  $m$  are the masses of the reduced product and the representative product.

$$K_{ser} = \left(\frac{N}{N_x}\right)^{0.15 \div 0.2} \quad (1.3)$$

where  $N$ ;  $N_x$  - annual programs of the product - the representative and the resulting product.

Below is the detailed annual production program of the machine shop.

All calculated and collected data are summarized in Table 1.1.

Table 1. 1 - List of manufactured products

Preset program				The resulted program					
Product name	Product designation	Number	Part weight	K <sub>w</sub>	K <sub>ser</sub>	K <sub>com</sub>	To	Representative	The given number of products
Landing gear section									
Lower link	148.00.4102.025.000	120	0.903	0.96	0.82	1	0.79	link	95
Upper link	148.00.4102.235.003	120	2.86	2.12	1.03	1	2.18		262
rocking chair	148.00.4104.212.002-01	230	1.72	1.34	0.68	1	0.91		210
Rocking chair	148.00.4104.212.002-02	230	1.72	1.28	0.32	1	0.41		95
Link	148.00.4104.231.000	60	2.18	1.6	0.87	1	1.39		83
Link	148.00.4104.271.000	60	0.643	0.43	1.09	1	0.47		28
Head	148.00.4111.001.000	90	1.77	1.76	0.73	1	1.28		115
Head nut	148.00.4111.002.000	90	0.835	0.92	0.94	1	0.86		77
<b>Cylinder</b>	<b>148.00.4111.303.000</b>	90	7.0	2.16	1.14	1	2.46		220
Stock	148.00.4111.311.000	80	6.18	3.92	one	1	3.92		314
Axis	148.00.4112.217.000	160	1.527	1.13	0.85	1	0.96		154
Lever arm	148.00.4112.301.002	90	9.24	4.45	0.92	1	4.09		368
Wheel axle	148.00.4112.302.000	180	7.32	2.17	1.06	1	2.3		414
bracket	148.00.4113.203.000	220	1.24	0.94	0.56	1	0.53		117
Strut axis	148.00.4113.206.000	200	0.125	one	0.74	1	0.74		148
Upper traverse assembly	148.00.4113.351.000	90	4.36	3.12	1.18	1	3.68		330
Middle traverse assembly	148.00.4113.352.000	60	6.85	2.4	1.12	1	2.69		161
Lower traverse assembly	148.00.4113.353.000	90	9.43	4.29	0.98	1	4.2		378
Link	140.00.4104.023.000	140	0.816	0.67	0.46	1	0.31		43
Link	140.00.4104.229.003	140	0.513	1.22	0.74	1	0.9		126
Axis	140.00.4112.032.000	180	8.12	5.38	0.62	1	3.34	600	
Screw	140.00.4211.104.000	120	2.145	1.87	0.67	1	1.25	150	
Cylinder	140.00.4211.209.000	80	1.457	0.915	0.73	1	0.67	54	
		2920							4542
Area "Shafts"									

Preset program				The resulted program					
Product name	Product designation	Number	Part weight	$K_w$	$K_{ser}$	$K_{com}$	To	Representative	The given number of products
Pinion shaft	00.1507.2100	120	11.0	1	1	1	1	pinion shaft	120
Shaft stepped	00.4899.2000	200	6.85	2.8	0.76	1	2.13		426
Splined shaft	03.4947.0000	200	5.78	1.4	one	1	1.4		280
Shaft	04.4957.3200	150	12.3	2.92	0.94	1	2.74		410
Axis	00.4880.2300	700	6.125	0.48	1.06	1	0.51		357
Mandrel	05.4866.0000	500	4.5	0.95	0.58	1	0.55		275
Coupling	00.1506.2100	1100	3.82	0.45	0.85	1	0.38		418
Pulley	08.0100.2100	900	3.64	3.87	0.29	1	1.12		1007
block gear	04.1507.2400	300	5.6	4.18	0.36	1	1.5		450
gear wheel	04.1507.1600	220	1.37	0.92	0.47	1	0.43		95
gear wheel	04.1507.2600	480	2.14	1.57	1.03	1	1.62		778
Total:		4870							4616
In all:		7790						9158	

We determine the reduced labor intensity of the shop [2]:

$$T_{work.} = T_{site}^1 + T_{site}^2 \quad (1.4)$$

where  $T_{site}^1$ ;  $T_{site}^2$  - the labor intensity of the workshop sections, is determined by the formula [2]:

$$T_{site}^n = \sum N_x^n \cdot T_{pcs}^{rep.} \quad (1.5)$$

where  $\sum N_x^n$  - the given program for the production of products on the site;

$T_{pcs}^{rep.}$  - the piece time of the product of the representative.

$$T_{site}^1 = 4542 \cdot 63,27 = 287372 \text{ standard time.} \quad T_{site}^2 = 4616 \cdot 42,21 = 194841 \text{ standard time.}$$

Then the labor intensity of the workshop is:

$$T_{work} = 287372 + 194841 = 482213 \text{ standard time.}$$

We take the actual (achieved) labor intensity  $T_f$ , which is determined by the formula [2] as the basis for calculating the machine-tool intensity:

$$T_f = \frac{T_n \cdot 100}{B} \quad (1.6)$$

where  $T_n$  - reduced labor intensity, standard time.;

$B$  - the average level of compliance with the norms in percent.

$$T_f = \frac{482213 \cdot 100}{98} = 492054 \text{ standard time.}$$

#### 1.4 Determining the type of production

The type of production depends on the annual program, the characteristics of products, the complexity of manufacturing parts. The annual production program is 90 pcs. The type of production is determined by the section "Cylinders".

According to tentative data, in our case, small-scale production. It is characterized by the manufacture of a limited range of products in batches (series), repeating at certain intervals, and a wide specialization of jobs.

The release cycle is determined by the formula [1]:

$$t_r = \frac{F_g \cdot 60}{N} \quad (1.7)$$

where  $F_g$  is the actual annual equipment time fund, in hours,

$$F_g = 4060 \text{ h ;}$$

$N$  is the annual program for the production of parts, pcs.

$$\tau = \frac{60 \cdot 4060}{90} = 2707 \text{ min for cylinder.}$$

The serialization coefficient  $K_c$  is determined by the formula [1]:

$$K_c = \frac{\tau}{T_{pcs.av}} \quad (1.8)$$

where  $T_{pcs.av}$  - the average piece time for the main operations on the site, is determined by the formula [1]:

$$T_{pcs.av} = \frac{\sum_{i=1}^n T_{pcs.i}}{\sum n} \quad (1.9)$$

where  $T_{pcs.i}$  - piece time of the  $i$ -th operation;

$n$  - the number of basic operations of the technological process.

$$T_{pcs.av.site."Cylinder"} = \frac{484,53}{4} = 121,13 \text{ min};$$

$$K_{s.site."Cylinder"} = \frac{2707}{121,13} = 22,35.$$

If the serialization coefficient satisfies the condition  $20 < K_s < 40$ , then the type of production is small-scale. Since in our case  $K_s = 22.35$ , the type of production is small-scale. Small-scale production is characterized by a lack of continuity and stability in the range of manufactured homogeneous products; a large range of manufactured products; the lack of fixing operations for a specific machine. This type of production is characterized by a non-linear method of production [2; 3], i.e. equipment is located according to the principle of uniformity of processing (turning section, milling section, etc.) or in the sequence of technological operations for one or more parts. Parts are processed in batches, the time for performing operations on some machines is not coordinated with the time of operation on others, and the parts are stored at the machines during operation and then transported as a whole batch. Location equipment is accepted in the workshop design section. Therefore, we determine the size of the batch of parts launched into production.

Lot size parts is determined by the formula [1]:

$$n = \frac{N \cdot f}{F} \quad (1.10)$$

where  $N$  is the annual program for the production of products in pieces;

$f$  - the number of days for which it is necessary to have a stock of parts in stock,  $f = 24$  days;

$F$  - the number of working days in a year,  $F = 253$ .

$$n = \frac{90 \cdot 24}{253} = 8,54 \text{ PCS.}$$

We accept a batch of launching parts into production  $n = 10$  PCS.

In this workshop we accept one-station maintenance equipment. We use hand trucks for transporting parts on site.

### 1.5 Analysis of technological processes of the base plant

The basic technological processes for manufacturing a cylinder are presented in the form of table 1.2

#### 1.5.1 Routing process of the base cylinder processing plant

The route process for manufacturing the cylinder of the base plant is shown in Table 1.2

Table 1.2 - Route technical process of the base plant for the processing of the cylinder

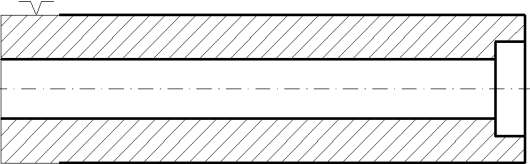
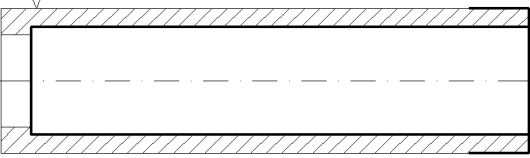
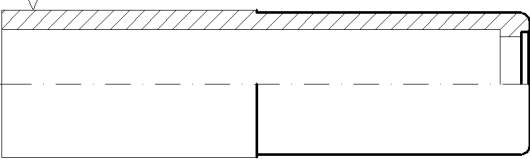
No. operations	the name of the operation	Scheme of setting the workpiece on the machine	Name and model of equipment
010	Turning		Lathe Heid-630
015	Turning		Lathe Heid-630
020	Turning		Lathe E-120

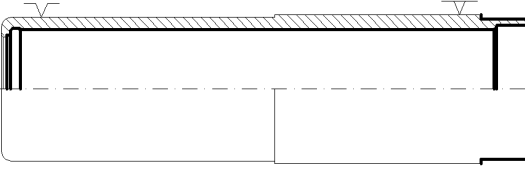
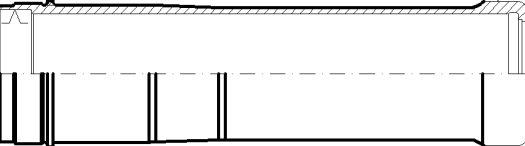
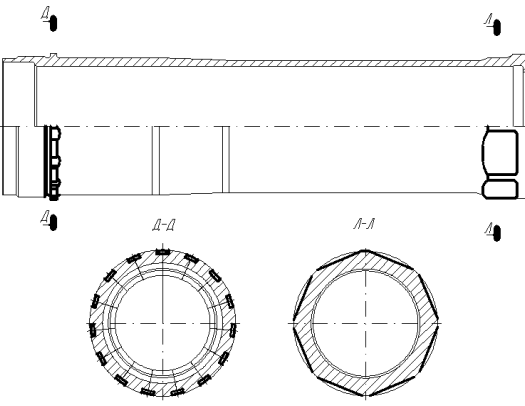
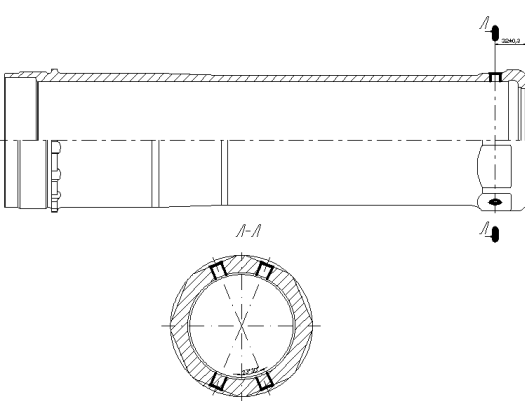
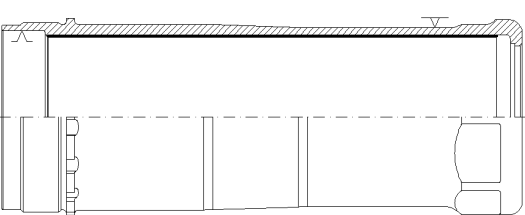
No. operations	the name of the operation	Scheme of setting the workpiece on the machine	Name and model of equipment
025	Turning		Lathe E-120
030	Turning		Lathe E-120
035	Milling		Milling and drilling machine 2201VMF4
040	Drilling		Milling and drilling machine 2201VMF4
045	Grinding		Internal grinding machine 3K229A

## **1.5.2 Suggestions for improving factory processes**

In the basic technological process, we can make some changes regarding the workpiece. For the manufacturing of a cylinder, it is rational to use a blank forging on horizontal forging machines, which will significantly increase the material utilization rate, as well as reduce the number of operations and reduce the labor intensity of manufacturing parts.

In the example of a cylinder, there is no need to drill a hole, which increases the utilization of the material.

Also, the use of special devices can be introduced into the basic technological process, while reducing the cost of manufacturing tooling.

To reduce the production of defective parts, it is necessary to introduce timely control of sharpening of the cutting tool into the technological process and tighten the quality control of blanks, since the quality of the blank affects the percentage of rejects (the presence of shells, material junctions, etc.).

In addition, it is necessary to introduce a complete replacement of the lubrication cooling equipment (LCE) brand with Blasocut 4000 Strong in the basic technical process. The cost of Blasocut 4000 Strong LCE, although it is three times higher compared to Ukrinol-1M LCE, however, the period of its use in work is two years, unlike Ukrinol-1M LCE - two months. In addition, Blasocut 4000 Strong LC showed the best results in the processing of titanium alloys, which is presented in a special part of the graduation project.

## 2 TECHNOLOGICAL SECTION

### 2.1 Process design

#### 2.1.1 Selecting a method for obtaining blanks

Selection of the method for obtaining the workpiece of the “Cylinder” part.

As a blank for the “Cylinder” part, a  $\varnothing 150$  mm bar made of titanium alloy VT22 is accepted at the base enterprise.

After analyzing the shape of the “Cylinder” part, we come to the conclusion that the cylinder blank can be obtained on horizontal forging machines.

We compare the methods for obtaining a workpiece to select the most rational one.

To calculate the dimensions of the forging, we determine the initial index according to EN 10243-1. Its definition depends on the calculated forging mass  $M_{PR}$ , steel grade M1-M3, degree of complexity C1-C4 and accuracy class of the forging.

Estimated weight of the forging:

Calculated coefficient  $K_p$  from [3] for group 5 (parts with holes) is 1.8 - 2.2.

Accept  $K_p = 2.0$ .

Then estimated forging weight

$$M_{PR} = 7.0 \times 2.0 = 14,0 \text{ kg.}$$

Define the steel group.

With a total mass fraction of alloyed elements above 5%, the VT22 alloy belongs to the M3 group.

We determine the degree of complexity by calculating the mass (volume)  $G_v$  of the forging to the mass (volume)  $G_F$  of the geometric figure into which the shape of the forging fits. For a given part, such a geometric figure is a cylinder.

Forging volume

$$G_P = M_{PR} : \rho = 14,0 : 4500 = 0,003111 \text{ m}^3.$$

The volume of the geometric figure into which the forging shape fits can be increased by a factor of 1.05 relative to the overall linear dimensions of the part, which determine the position of its machined surfaces. The overall dimensions of the part and the dimensions of the figure are entered in Table 2.1.

Table 2.1 - Overall dimensions of the part and dimensions of the figure.

Part dimensions		Figure dimensions	
Maximum diameter, mm	Maximum length, mm	Maximum diameter, mm	Maximum length, mm
146	530	153.3	556.5

Determine the volume of the cylinder shape

$$G_f = \frac{\pi d_{maxf}^2}{4} \cdot L_{maxf} = \frac{3,14 \cdot 0,1533^2}{4} \cdot 0,5565 = 0,01027 m^3.$$

$$\text{Then } G_P / G_F = 0.003111 / 0.01027 = 0.303$$

Since the ratio  $G_P / G_F$  from 0.16 to 0.32, then the degree of complexity of the forging is C3.

The results of the calculations are entered in table 2.2.

Table 2.2 - Calculation results

Estimated coefficient $K_r$	Estimated weight of the forging $M_{PR}$ , kg	Forging volume $G_P$ , $m^3$	The volume of the geometric figure $G_\Phi$ , $m^3$	Ratio $G_P / G_F$
2.0	14.0	0.00311	0.01027	0.303

We accept that receive a forging at the horizontal forging machines, then such conditions correspond to the accuracy class T5.

The initial index for the subsequent assignment of the main allowances is determined using [3]: the initial index is 19.

We determine the allowances for machining (per side) of forgings according to EN 10243-1 using [3].

The selected allowances and the calculated dimensions of the forging are entered in Table 2.3.

Table 2.3 - Allowances and estimated dimensions of the forging.

Nominal dimensions of the part, mm	Tolerance and deviations of the forging, which are allowed, mm		Machining allowance (per side), mm	The full value of the allowance, mm	Nominal forging size, mm
$\varnothing 146$	5.6	+3.7	3.5	7.0	$\varnothing 153.0$
		-1.9			
$\varnothing 105$	5.6	+3.7	3.5	7.0	$\varnothing 98.0$
		-1.9			
530	8.0	+5.3	3.7	7.4	537.4
		-2.7			

We carry out a technical sketch of the forging on A2 paper.

We execute a 3D forging model in a graphical editor and determine the volume:

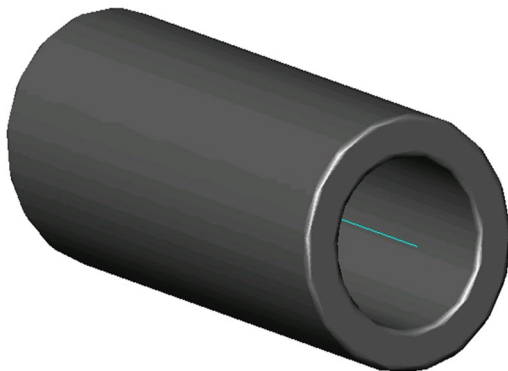

$$G_p = 0,00582 \text{ m}^3;$$

$$M_{bl} = G_n \times \rho = 0,00582 \text{ m}^3 \times 4500 \text{ kg/m}^3 = 26,19 \text{ kg}.$$

Figure 2.1. 3D model of the forging of the "Cylinder" part.

A blank made of a hot-rolled bar, taking into account machining allowances and selected from a series, has a mass:

$$m = \frac{\pi D^2}{4} \cdot l \cdot \rho = \frac{3,14 \cdot 15^2}{4} \cdot 53,5 \cdot 4,5 = 42,6 \text{ kg}.$$

Let's compare the material utilization rates for both methods

– for forgings

$$K_{V.T.1} = 7,00 / 26,19 = 0,267;$$

– for bar stock

$$K_{V.T.2} = 7,00 / 42,6 = 0,164 .$$

From a comparison of the values of  $K_{V.T.1}$  and  $K_{V.T.2}$ , we come to the conclusion that the first method is more rational, and we accept it.

## 2.2 Determination of the sequence of technological operations and the choice of equipment

### 2.2.1 Determining the sequence of technological operations

The set of execution of technological operations is the processing route. To draw up a processing route, we set a processing plan for the main surfaces of the part. The number of steps and methods of processing the main surfaces of parts are given taking into account reference [3; 4 ].

Table 2.4 - Plan for processing the main surfaces of the cylinder

Part surface	Surface drawing requirements		Surface parameters after processing		
	Accuracy	Roughness Ra	Technological transitions (operations)	Accuracy	Roughness Ra
Ø128H7	Ø128 <sup>+0.04</sup>	Ra 0.8	Blank Rough boring Fine boring Fine boring (diamond)	H14 H13 H10 H7	Ra 25 12.5 3.2 0.8
Ø120H7	Ø120 <sup>+0.035</sup>	Ra 0.2	Blank Rough boring Fine boring grinding	H14 H13 H10 H7	Ra 25 12.5 3.2 0.8
Ø136.2 <sup>-0.05</sup>	Ø136.2 <sup>-0.05</sup>	Ra 0.8	Blank Rough boring Fine boring Fine boring (diamond)	H14 H13 H10 H7	Ra 25 12.5 3.2 0.8
Ø132h11	Ø132 <sup>-0.25</sup>	Ra 3.2	Blank Rough turning Fine turning	h 14 h 13 h 10	Ra 25 12.5 3.2
12H11	12 <sup>+0.11</sup>	Ra 3.2	Blank Milling disposable	h14 h11	Ra 25 3.2

Part surface	drawing		Surface parameters after processing		
	Surface requirements	Roughness Ra	Technological transitions (operations)	Accuracy	Roughness Ra
136h11	132 <sup>-0.25</sup>	Ra 3.2	Blank Milling disposable	h14 h11	Ra 25 3.2
Ø146h12	Ø146 <sup>-0.63</sup>	Ra 3.2	Blank Rough turning Fine turning	h14 h13 h10	Ra 25 12.5 3.2
Ø137h12	Ø137 <sup>-1.0</sup>	Ra 3.2	Blank Rough turning Fine turning	h14 h13 h10	Ra 25 12.5 3.2
Ø144h12	Ø144 <sup>-1.0</sup>	Ra 3.2	Blank Rough turning Fine turning	h14 h13 h10	Ra 25 12.5 3.2
Sp140 ×2	Sp140 ×2	Ra 3.2	Blank Semi-finish turning Threading	h14 h12 h8	Ra 25 12.5 3.2
Ø105H12	Ø105 <sup>+0.87</sup>	Ra 3.2	Blank Rough boring Fine boring	H14 H13 H10	Ra 25 12.5 3.2
Ø109H12	Ø109 <sup>+0.54</sup>	Ra 1.6	Blank Rough boring Fine boring	H14 H13 H10	Ra 25 12.5 1.6
Ø122H12	Ø122 <sup>+1.0</sup>	Ra 1.6	Blank Rough boring Fine boring	H14 H13 H10	Ra 25 12.5 1.6
MR12 ×1- 5H6H	MR12 ×1- 5H6H	Ra 3.2	Blank drilling Countersinking Threading	H14 H12 H10 H8	Ra 25 12.5 3.2 3.2

According to the accepted processing plan, we draw up a route technological process and draw up route maps in accordance with GOST 3.1105-74 (see Appendix A, B).

The accepted equipment is entered in the appropriate columns of the route map.

### 2.2.2 Rationale for accepted equipment

Taking into account the type of production (small-scale) and the complexity of the manufactured parts, we accept CNC machines and machining centers that

allow for complex processing of shaped surfaces of parts, obtain high labor productivity and are easily readjusted.

The cylinder is a fairly large part of the "Hollow cylinders" class with a mass of 7 kg. Forging billet obtained at horizontal forging machines. The workpiece surfaces are pre-treated and then used as base surfaces.

The decisive factors in the choice of equipment are to ensure the specified accuracy and quality of the machined surfaces with maximum labor productivity, the overall dimensions of the machined parts and the possibility of processing automation.

Machines are selected according to the catalogs indicating the type and model in the route technological process.

The use of special machines is advisable, since the cylinder is a rather complex part in configuration, they are made of high strength material (machinability titanium alloys are characterized by their low ductility, high chemical activity during cutting, low thermal conductivity) and are parts of the critical part of the aircraft.

For the processing of our part, we use one machine, a CNC Turning and Milling Center Kovosvit MAS MultiCut 500i. All turning, milling and drilling operations will be performed on this machine in one setup with interception in the sub- spindle and steady rest.

Figure 2.2 MULTICUT 500i (S) [50]



Table 2.5 TECHNICAL DATA MULTICUT 500i (S) [50]

<b>OPERATING RANGE</b>	unit	value
Max. swing over bed / lower support	mm	1030
Max . turning diameter B=0° / 45° / 60° / 90°	mm	549 / 690 / 880 / 1030
Max. distance of faces spindle to tailstock spindle   spindle to spindle	mm	1799
Max . turning length	mm	1527
bar work capacity	mm	94
<b>WORKPIECE WEIGHT</b>		
Not supported / supported with center (max. speed) with a chuck	kg	800 / 2100
Supported with steady rests 1 (max. speed 300 min <sup>-1</sup> )	kg	2500

<b>LINEAR AXES OF THE TOOL SPINDLE</b>		
X / Y <-Y/+Y> / Z axis travel	mm	640 / 370 <-190+180> / 1600
Feed force X ; Y ; Z 25% / 40%ED / continuous	kN	21.5 / 17.5 / 12.5; 19.5 / 16 / 11.5; 32/27.5/17
X / Y / Z axis rapid traverse	m.min <sup>-1</sup>	50 / 40 / 50
X / Y / Z axis acceleration	ms <sup>-2</sup>	5 / 4 / 5
<b>MAIN SPINDLE</b>		
low speed	min <sup>-1</sup>	3500
high speed	min <sup>-1</sup>	3500
Nominal spindle speed	min <sup>-1</sup>	750
gear box stages		one
Spindle nose type (DIN 55026)		A8
Spindle boring	mm	106
ID of the front bearings	mm	160
<b>TOOL SPINDLE</b>		
Max . speed	min <sup>-1</sup>	12 000
Nominal speed	min <sup>-1</sup>	2100
Taper	kVa	HSK-63 / Capto 6
Torque 25% / 40% ED / continuous	Nm	123 / 100 / 60
Power 25% / 40% ED / continuous	kW	27/22/13
number of tool indexing positions		360 x 1°
Spindle length	mm	563
<b>TOOL STORE</b>		
Tool storage capacity		81

Max . tool length	mm	350
Max. tool diameter with / without adjacent HSK-63, Capto C6	mm	150 / 90
Max . tool weight	kg	eight
Tool to tool / chip to chip change time	s	3 / 15
<b>MACHINE DIMENSIONS</b>		
Machine length without / with chip conveyor / for transport	mm	4800 / 6500 / 5372
machine width / for transportation	mm	3950 / 3670
machine height / for transportation	mm	3760 / 3660
machine weight	kg	23 050
<b>MACHINE CONNECTION</b>		
Electrical power supply / continuous	kVA	110
Compressed air supply / pressure / flow	MPa /L.min <sup>-1</sup>	0.6 / 600
<b>CONTROL SYSTEM</b>		
Type		Siemens Sinumerik 840D SL
Number of continuously controlled axes for machining		5

### 2.3 Selection and justification of technological and measuring bases

Based on the analysis of the technical requirements for the part and its operating conditions, we identify the technological bases for all the proposed processing operations.

The choice of bases for subsequent processing is based on the fact that the highest accuracy of processing is achieved when using the same base surfaces for all machining operations, that is, observing the principle of constancy of bases.

For the cylinder, we accept the following technological bases:

- at the first operation, we process the end face and the outer cylindrical surface, which will be used as technological bases at the subsequent operation;
- in subsequent operations, the surfaces obtained in the previous operation are used as technological bases.

## **2.4 Design of the operational process**

Based on the accepted route technological processes for processing the cylinder, we develop operational technological processes [5] for each transition operation (see Appendix A, B).

Operational cards are filled in according to all columns of the forms established by the system of technical documentation.

Operational sketches are made to any scale. The number of projections is determined by the need to show all the surfaces to be machined and the operating dimensions, i.e. to have a complete picture of the workpiece.

The detail on the operational sketch is drawn in the working position that it occupies on the machine, and in the form that it has after processing in a particular operation. The basing and fastening of the part in the fixture is shown by symbols in accordance with GOST 3.1107-81.

Machined surfaces are indicated by thick lines. The operational sketch indicates the resulting dimensions with tolerances and surface roughness.

Taking into account possible deformations as a result of the redistribution of internal stresses, we first process surfaces that do not have strict requirements for accuracy, and then more accurate surfaces.

Operation cards and sketch cards with complete information about the technological process are in Appendix A, B.

## **2.5 Selection of fixtures, cutting tools and engineering controls**

### **2.5.1 Selection of fixtures and auxiliary tools**

The choice of fixtures and auxiliary tools is made for each operation separately. The device must provide the necessary processing accuracy, high performance, safety and economy. Since the plant has an extensive compressed air system, we use pneumatic devices for processing.

When processing parts on CNC lathes, we use standard and special three-jaw chucks [11; 12]. They provide reliable fastening of the part, sufficient accuracy of fastening the part, sufficient position accuracy, speed when fastening and removing the part. When using these devices, the cost of manufacturing parts is reduced.

During milling and drilling operations of the cylinder, special single-seat fixtures are used, which allow achieving the highest productivity and economy, labor safety, as well as ease of use.

For locksmith operations, we use a universal vice with a mechanical clamp, since their use in these operations does not require high processing accuracy.

After selecting the necessary devices in the appropriate columns of operational cards, we indicate their name.

### **2.5.2 Choosing ISO cutting tools**

The choice of cutting tools was carried out taking into account the nature of production, processing method, type of machine, configuration, dimensions, material of the workpiece being processed, the required surface quality and processing accuracy.

Depending on the type of processing, a standard cutting tool is used in the designed technological process:

- HG 40 hard alloy inserts are used;
- for drilling - tools made of high-speed steel S 10-4-3-10, designed for processing high-strength alloys in conditions of increased heating;

- for milling flats and grooves in the cylinder, cutters made of hard alloy HG 40 and high-speed steel S 10-4-3-10 are used;
- for threading in the holes of the cylinder, rough and finishing taps made of steel HS 6-5-2-5 are used;
- HG 40 carbide insert;
- for turning chamfers and radii, specially designed and reground cutters with HG 40 carbide inserts are used;
- to dull sharp edges and remove burrs, a file and scraper are used.

Since the operating conditions of the tool on CNC machines differ from the operating conditions of the tool on conventional machines, the share of cutting time in the total operating time increases to 45-75%. This reduces the tool life and increases the consumption of the cutting tool, therefore, considering the operating conditions, when choosing cutting tools, you must be guided by the following:

- for turning, use cutters with mechanical fastening of multi-faceted non-returnable quick-change carbide inserts. In the designs of through cutters, tetrahedral inserts with a leading angle of  $45^\circ$  are used;
- for shoulder milling, flat and shaped surfaces of the head, use milling cutters with non-sharpenable quick-change carbide inserts from TaeguTec, Hoffmann group.

Accepted cutting and auxiliary tools for each operation are indicated in the attached technological process (Appendix A).

### **2.5.3 Selection of engineering controls**

When designing this technological process in relation to the means of technological control, the following rules are taken into account. Since the main part of the operations is performed on CNC machines, the dimensional accuracy is ensured technologically, without means of control, especially for dimensions that cannot be measured. If it is impossible to do without technological controls, active controls will be used in order to eliminate or reduce to a minimum the time for technical measurements. To measure the diameters of external surfaces, holes and

lengths, universal tools and devices are used, which include: caliper tools, measuring heads, micrometric tools.

The accepted means of control, depending on the accuracy of the controlled parameters for each operation, are recorded in technological cards (Appendix A, B) indicating their name, measured size, DIN or normal for the manufacture of these tools [10].

## 2.6 Selection and calculation of processing modes

At the operation, we select the processing modes according to the reference book [13, 14] and enter them into the operating charts.

The results of the selection of cutting modes for the remaining operations are summarized in Table 2.6.

Table 2.6 Cylinder Machining Mode Summary

Number operations	transitions	Name of operation and transition	Processing modes						
			D (B), mm	L mm	t, mm	i	S, mm/rev	V, m/min	n, rpm
015	<b>Turning</b>								
	1	Rough cutting of the end	151	80	3.0	1	0.3	76.4	160.71
		Fine cutting of the end	151	80	1, 0	1	0.11	86.7	182.37
		Rough turning of the outer cylindrical surface	145.4	250	3.0	1	0.21	59.96	131.33
		Fine turning of the outer cylindrical surface	144	250	0.7	1	0.1	87	192.4
	2	Rough boring of the inner surface	106	9	2.5	1	0.38	71.3	214.22
Fine boring of the inner surface		105	9	0.5	1	0.18	92.7	281.16	
030	<b>Turning</b>								
	1	Rough cutting of the end	151	80	3.2	1	0.24	76.4	160.7
	2	Fine cutting of the end	151	80	1.4	1	0.11	86.7	182.37
	3	Rough turning of the outer cylindrical surface for threading	142.4	47.5	4.5	1	0.21	60	134.19
	4	Fine turning of the outer cylindrical surface for threading	141	47.5	0.7	1	0.12	82	185.2
	5	Rough boring of the inner surface	119	520.5	5	1	0.1	64.2	171.8

Number		Name of operation and transition	Processing modes						
operations	transition		D (B), mm	L mm	t, mm	i	S, mm/rev	V, m/min	n, rpm
	6	Fine boring of the inner surface	120.5	520.5	0.5	1	0.06	78.6	208.6
	7	Fine (diamond) boring of a hole	120.25	520.5	0.25	1	0.02	94	248.95
	8	Grooving	122	10	1.0	1	0.1	84	219.28
	9	Hole boring	109	3.5	2.0	1	0.1	84	245.43
	10	Rough boring of a hole	129	32	3.0	1	0.12	60	148.13
	11	Fine boring of a hole	128.5	32	0.5	1	0.07	78	193.3
	12	Fine (diamond) boring of a hole	128	32	0.25	1	0.06	92.2	229.4
	13	Rough turning of the outer cylindrical surface	138.4	416	5	1	0.21	60	138.1
	14	Rough turning of the outer cylindrical surface	137	416	1.4	1	0.12	82	190.6
	15	Rough turning of the outer cylindrical surface	147.4	6	four	1	0.21	60	129.6
	16	Rough turning of the outer cylindrical surface	146	6	1.4	1	0.12	82	178.9
	17	Rough turning of the outer cylindrical surface	133.4	245	1.8	1	0.29	74	176.7
	18	Rough turning of the outer cylindrical surface	132	245	1.4	1	0.12	82	197.8
	19	One-time taper turning	-	63	-	1	0.1	80	186.6
	20	Threading	Sp 140 ×2	31	1.9	1	2	64.8	147.4
035		<b>Milling and drilling</b>							
	1	Flat milling	-	47	4	8	0.8	22	140
	2	Milling 15 slots	12	6	4.2	15	0.24	24	637
	3	Drilling 4 tapping holes	10.2	14	5.0	1	0.06	17	530.8
	4	Countersinking of 4 holes for threading	11.2	14	0.5	1	0.12	8.4	238.85

### **3. SPECIAL SECTION**

#### **3.1 Choice of technological equipment**

##### **3.1.1 Analysis of source data**

The part is made of material - VT22. The overall dimensions of the part [ $\varnothing 144 \times 530$ ] and the equipment used indicate the use of a special machine tool. According to the route technological process, a special machine tool is designed for a turning operation. The selected machine tool will be used to machine the outer and inner cylindrical surfaces of the cylinder. Attachment is installed on the multifunctional machining center model MultiCut 500i .

Selected special tool is Samchully 3 -jaw pneumatic chuck.

The main advantage of pneumatic chucks is that they are fast acting and provide a constant clamping force on the jaws.

When working in manual chucks, in order to prevent loosening of the clamp and slippage of the workpiece during processing, it is necessary to clamp the part with a force greater than necessary. In pneumatic chucks, the cams compress the product with the same force all the time and any random circumstances that arise during operation cannot loosen the clamp.

The gear ratio in the mechanism of pneumatic cartridges is taken in the range from 1:1 to 1:4 (in manual cartridges, the gear ratio is of necessity taken large), so pneumatic cartridges have a high efficiency.

Pneumatic chucks are easily controlled, require negligible effort to clamp, and reduce the physical fatigue of the worker. The main advantage of pneumatic chucks is fast clamping.

The shape, quality of the treated surfaces, the requirements for their accuracy and relative position allow the use of this type of equipment and the use of a special device. The shape of the workpiece does not require the development of large and complex fixture elements. This device does not interfere with the supply of cutting, measuring tools to the surfaces to be machined.

To determine the possibility of executing a given production program, we determine the cycle according to the formula (1.6), section 1:

$$\tau_v \leq 2040 \text{ min.}$$

Checking the condition:

$$T_{\text{pcs.t}} \leq \tau_v,$$

where  $T_{\text{pcs.t}}$  - piece time, min.

$$T_{\text{pcs.t}} \leq 2040$$

the condition is met, which means that the production program is executed using a single machine fixture.

We accept the scheme of basing the part, taking into account the decisions made earlier, a single fixture, a three- jaw pneumatic chuck, see fig. 3.1.

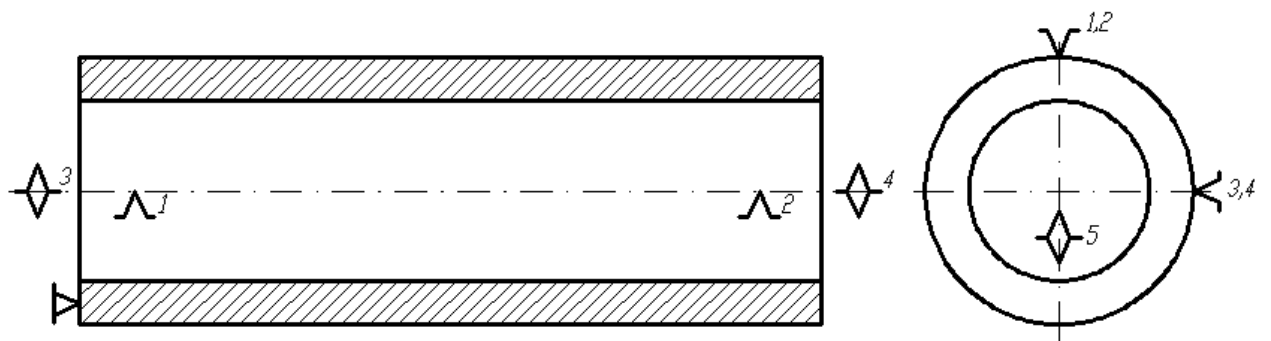

Figure 3.1. Scheme of basing the workpiece in the fixture

When fixing a part in a 3-jaw chuck and steady rest, the following scheme is implemented: connection  $C_{1,2,3,4}$  - double guide base ( $C_{1,2,3,4} S_{y,z}$ ,  $R_{ot y,z}$ ), connection  $C_5$  - support base ( $C_5 S_x$ ).

The setting elements for the implementation of the adopted basing scheme are - a set of cams (raw and hardened) [12].

Since the selected chuck is a three- jaw chuck , the number of setting elements is predetermined - 3 cams. The dimensions of the accepted installation elements are shown below, Figure 3.2.

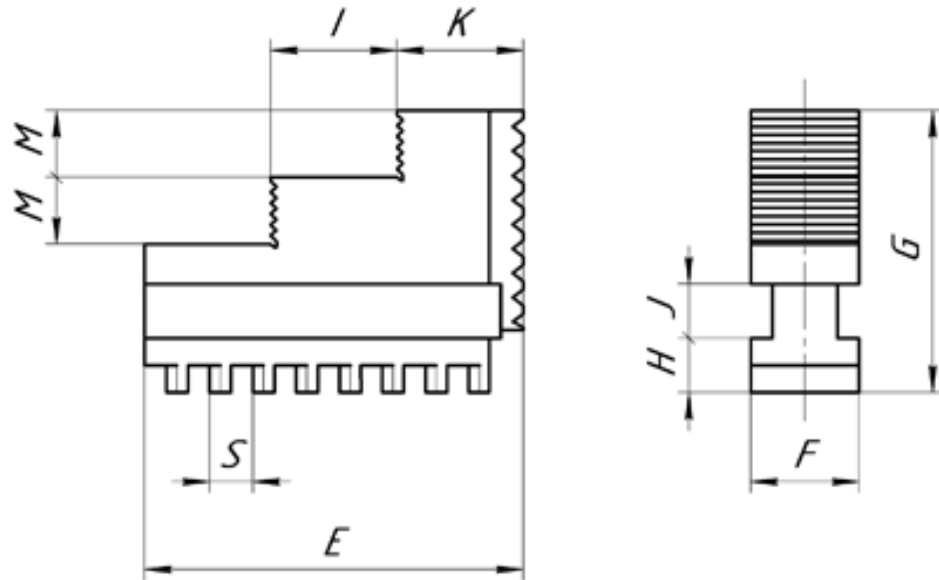

Figure 3.2. Lathe chuck jaw

We select cams with standard sizes:  $E = 85 \text{ mm}$ ,  $F = 28 \text{ mm}$ ,  $G = 60 \text{ mm}$ ,  $H = 8.5 \text{ mm}$ ,  $J = 10 \text{ mm}$ ,  $K = 29 \text{ mm}$ ,  $L = 29 \text{ mm}$ ,  $M = 14 \text{ mm}$ ,  $S = 8 \text{ mm}$ .

The mutual arrangement of the mounting elements, as well as their position relative to the base surfaces, is determined according to the drawing of the part.

### 3.1.2 Force calculation fixture

In the process of processing specified surfaces (boring), the workpiece and fixture elements will be affected by the cutting  $P_Z = 10 \cdot C_p \cdot t^x \cdot S^y \cdot V^n \cdot K_p = 10 \cdot 300 \cdot 5^1 \cdot 0,09^{0,75} \cdot 64,2^{-0,15} \cdot 1,7 = 2244,36N$ , the clamping force  $Q$  and the friction force created by it  $F_{TP}$ .

The force of gravity  $G$  can be neglected. We accept the friction coefficient  $f = 0.16$ , because the workpiece is in contact with the clamping element.

To compensate for possible random deviations of force factors from the calculated (average) values, a safety factor is introduced into the force calculation [15]:

$$K = K_0 \cdot K_1 \cdot K_2 \cdot K_3 \cdot K_4 \cdot K_5 \cdot K_6, \quad (3.1)$$

where  $K_0 = 1.5$  - guaranteed safety factor;

$K_1 = 1 \div 1.2$  - takes into account the state of the base surfaces;

$K_2 = 1 \div 1.9$  - takes into account the blunting of the tool;

$K_3 = 1 \div 1.2$  - takes into account the shock load on the tool;

$K_4 = 1 \div 1.3$  - takes into account the stability of the forces developed by the drive;

$K_5 = 1 \div 1.2$  - takes into account the convenience of controlling manual clamping mechanisms;

$K_6 = 1 \div 1.5$  - takes into account the certainty of the location of the reference points when the workpiece is displaced by the moment of forces.

$$K = 1,5 \cdot 1,2 \cdot 1 \cdot 1 \cdot 1 \cdot 1,5 = 2,7.$$

We determine the most unfavorable situation, in which the loss of the stationary position of the workpiece is most likely, according to Figure 3.3.

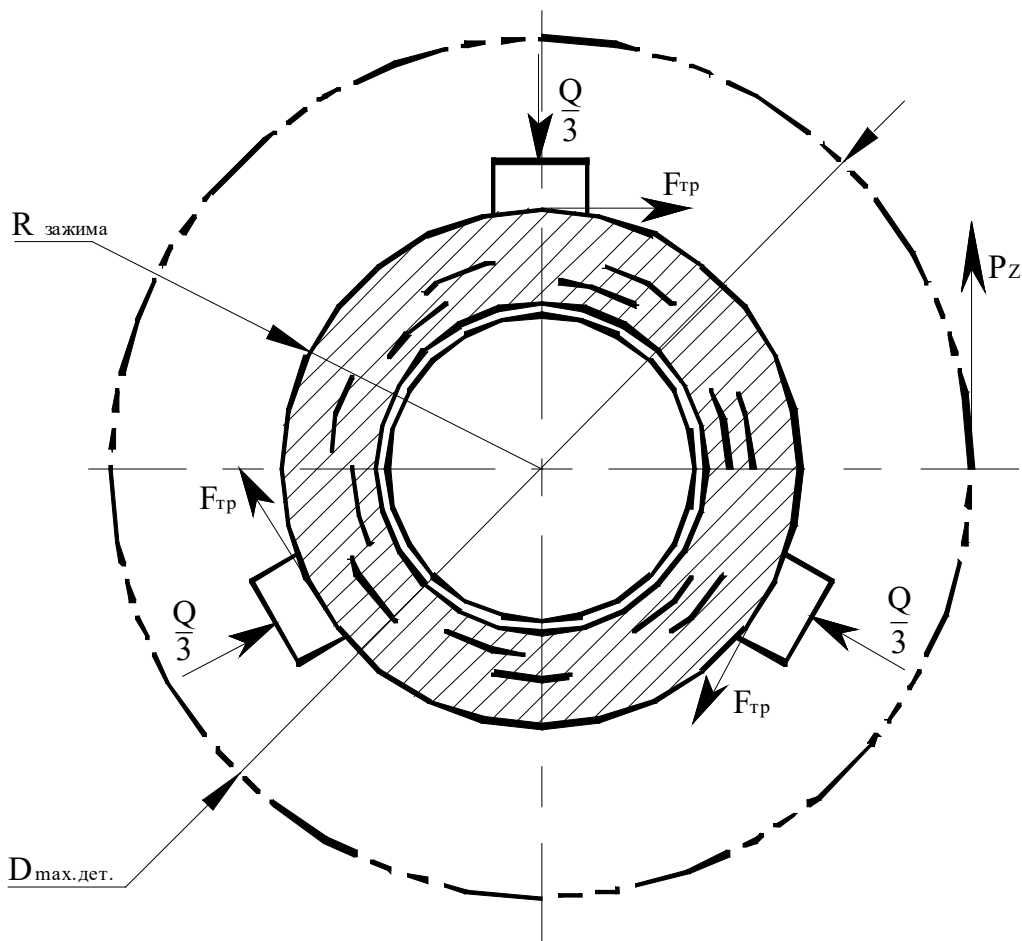

Figure 3.3. Scheme for determining an unfavorable moment

The unfavorable moment is the rotation of the workpiece around its axis under the action of the force  $P_z$ . Turning occurs from the moment created by the cutting force when turning the largest diameter of the workpiece. When machining smaller diameters of the workpiece, the torque from the cutting force is less and the rotation of the part is eliminated. Therefore, the clamping force must be greater than the moment created by the cutting force in order to create the necessary frictional force.

$$K \cdot P_z - 3F_{TP} \cdot R_{cl} = 0, \quad (3.2)$$

where  $K$  is the safety factor ( $K=2.7$ );

$P_z$  - cutting force.

$$F_{TP} = N \cdot f = Q \cdot f \quad (3.3)$$

Substituting into the formula for balancing forces, we get:

$$K \cdot P_z \cdot R - 3Q \cdot f \cdot R = 0, \text{ therefore } Q = \frac{K \cdot P_z}{3f}.$$

We find the clamping force of the workpiece:

$$Q = \frac{2,7 \cdot 2244,36}{3 \cdot 0,16} = 12624,53 \text{ N.}$$

For further calculations, we accept  $Q = 12700 \text{ N}$ .

Having the force of fixing the workpiece, we take the form of a clamping mechanism; we determine the transmission coefficient and calculate the clamping force. The clamping mechanism converts the force developed by the drive into a workpiece clamping force. We accept a pneumatic drive of the device, as this ensures a uniform clamping force and speed of the drive. The type of drive, initially we accept, is diaphragm. To select the type of clamping mechanism, select the circuit diagram of the fixture (Figure 3.4) and calculate the drive.

The mechanism is screw. Therefore, when determining the drive force, it is necessary to take into account the transfer forces of the elementary mechanisms that are part of the designed mechanism (Figure 3.5).

Since there are three clamping elements, the clamping force is also divided into three parts.

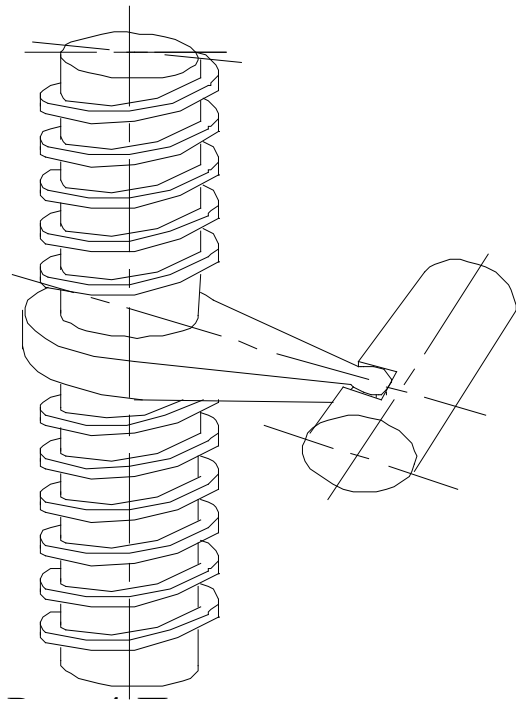

Figure 3.4. Device principal scheme

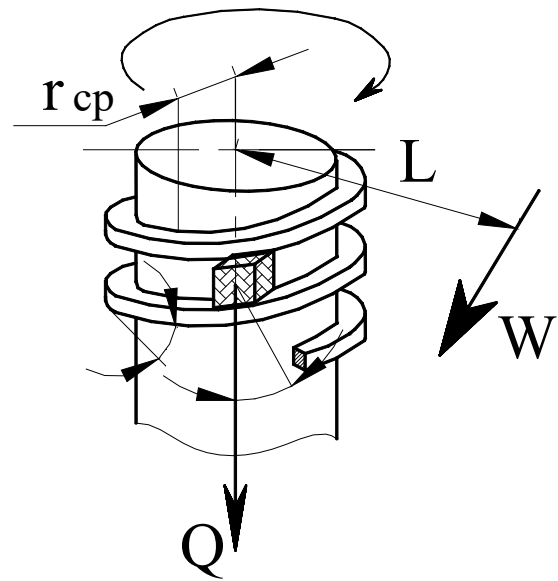

Figure 3.5. Transmission forces of the lever-wedge mechanism

The moment created by the force  $Q$  turns the screw around its axis, and the screw transmits the clamping force  $W$  along the thread to the cam that clamps the part.

The thrust force of the drive is determined by the expression [15]:

$$W = \frac{Q}{i \cdot \eta}, \text{ N} \quad (3.4)$$

where  $Q$  is the workpiece clamping force, N;

$i$  - the gear ratio of the lever-wedge mechanism is [15]:

$$i = \frac{r_{av.}}{L \cdot \tan \alpha}, \quad (3.5)$$

where  $L$  is the length of the lever, mm;

$r_{av.}$  - the average radius of the thread, mm;

$\alpha$  - the angle of friction in the pair.

We accept a trapezoidal thread, since we need to have a self-braking condition so that the part does not self-press.

According to the condition of self-braking:

$$f = 0,13 \geq \operatorname{tg} \tau,$$

where  $f$  is the coefficient of friction;

$\tau$ - the angle of elevation of the helix.

$$\operatorname{tg} \tau = \frac{S_{thr.}}{\pi \cdot D_{av.}} \quad (3.6)$$

The thread diameter is:

$$D_{cp} \geq \frac{S_{thr.}}{\pi \cdot 0,13} \quad (3.7)$$

Then

$$D_{av.} \geq \frac{12}{\pi \cdot 0,13} = 29,4 \text{ mm}.$$

We accept a trapezoidal thread Ladder. 32  $\times$  (6  $\times$  2) ISO 2904.

The friction angle is determined by the formula

$$\alpha = \operatorname{arctg} \frac{s}{2\pi \cdot r_{av.}}, \quad (3.8)$$

$$\operatorname{tg} \alpha = \frac{6}{3,14 \cdot 29} = 0,0658$$

The gear ratio is:

$$i = \frac{14,5}{30 \cdot 0,0658} = 7,34.$$

The pull force is:

$$W = \frac{12700}{7,34 \cdot 0,8} = 2163N$$

We accept  $W = 2200N$ .

The value of the diameter of the working cavity is determined by the formula [15]:

$$\text{Accept } \frac{d}{D} = \alpha = 0,46$$

$$\frac{\pi D^2(1-\alpha^2) \cdot p}{4} = W \Rightarrow D = \sqrt{\frac{4W}{\pi(1-\alpha^2) \cdot p}}, \quad (3.9)$$

where  $W$  is the traction force, N;

$p$  is the pressure of the working medium, Pa.

$$D = \sqrt{\frac{4 \cdot 2200}{3,14(1-0,46^2) \cdot 0,4 \cdot 10^6}} = 0.094m = 94mm.$$

Taking into account the calculated diameter of the working cavity, we accept  $D = 100$  mm.

In this way, strength clamping parts in drive is created using a single rod double acting pneumatic cylinder ISO 6431, piston diameter is taken equal to 100 mm, diameter stock 25 mm, static force on stock: pushing - 2700N, pulling - 2550N.

### 3.1.3 Evaluation of fixture accuracy

We check the device for accuracy according to the condition [15]:

$$\varepsilon \leq [\varepsilon], \quad (3.10)$$

where  $[\varepsilon]$  is the admissible value of the fixture error,  $\mu\text{m}$ ;

$\varepsilon$ - the actual value of the error of the device, microns.

$$[\varepsilon] = T - \kappa_t \cdot \varpi, \quad (3.11)$$

where T is the size tolerance,  $T = +0.035$ ;

$\kappa_t$ - tightening coefficient, 0.3 - 0.6;

$\varpi$ - the average economic accuracy of this type of processing is determined by reference [6].

$$[\varepsilon] = 35 - 0,3 \cdot 10 = 32\mu\text{m}$$

The fixture error is [15]:

$$\varepsilon = \sqrt{\varepsilon_b^2 + \varepsilon_f^2 + \varepsilon_p^2}, \quad (3.12)$$

where  $\varepsilon_b$  is the basing error;

$\varepsilon_f$ – fixing error;

$\varepsilon_p$  is the position error.

The basing error is:

$$\varepsilon_{\bar{o}} = 0,5 \cdot TD = 0,5 \cdot 35 = 17,5\mu\text{m}$$

The fixing error is zero, since the line of action of the fixing force is perpendicular to the direction of the size being performed (boring a hole).

The position error is equal to the wear error of the adjusting elements.

$$\varepsilon_{II} = \sqrt{\varepsilon_m^2 + \varepsilon_f^2 + \varepsilon_w^2}, \quad (3.13)$$

where  $\varepsilon_m$  - the manufacturing error of the adjusting elements, 5  $\mu\text{m}$ ;

$\varepsilon_f$  - error of fixture installation on the machine 7  $\mu\text{m}$ ;

$\varepsilon_w$  - the error of linear wear of the adjusting elements is equal to zero.

$$\text{Then: } \varepsilon_{II} = \sqrt{5^2 + 7^2} = 8,6\mu\text{m} \quad \varepsilon = \sqrt{17,5^2 + 0^2 + 8,6^2} = 19,5\mu\text{m}$$

Checking the condition:  $19,5\mu\text{m} \leq 32\mu\text{m}$ .

The condition is met, then the selected fixture provides the necessary processing accuracy.

### 3.2 ISO cutting tool

To perform each projected operation, the necessary cutting tool is selected. This is guided by the following considerations:

- the tool must provide the required accuracy and quality of the machined surfaces, as well as the necessary productivity and profitability.

The use of a particular tool is dictated by the following factors: surface treatment method, types of machine tool and technological equipment, configuration and dimensions of the workpiece, material being processed, type and level of organization of production, etc. In single and serial production, preference is given to a universal (purchased) tool.

For the correct choice of cutting tool when turning, it is necessary to know the design features of turning tools.

It is most convenient to consider the design features of turning cutters using the example of a turning straight through cutter. The turning tool consists of two parts - the working part and the core (body). The rod is designed to mount the cutter on the machine. The working part is characterized by surfaces, edges and vertices. The front surface during cutting is in contact with the cut layer of the workpiece and chips. The main rear surface is facing the cut of the workpiece surface to be machined. Auxiliary rear surface facing the machined surface of the workpiece. It should be noted that the chips come off only along the front surface, the back

surfaces do not participate in the cutting process, but only contact with the surfaces of the workpiece. The intersection of the front surface with the main rear surface forms the main cutting edge, and with the auxiliary rear - the auxiliary cutting edge. The top of the cutter is the intersection of the main and auxiliary cutting edges.

The choice of a cutting tool for turning begins with an analysis of the task. First of all, you need to choose the type of cutter. The type of cutter is selected depending on the shape of the surface being machined.

After selecting the type of cutter, it is necessary to select the tool material and the corresponding parameters of the angular geometry of the tool. The material of the cutting part of the tool is selected depending on the type of turning and the material of the workpiece.

Table 3.1 Cutting tool and cutting conditions

No. operations	the name of the operation	Name tool	Modes cutting
010	Turning (roughing)	Toolholder Korloy DWLNR 2525-M 08 with WNMG insert - GR 080412- GR PC5300 _	T = 3-4 mm, S rev = 0.2-0.5 mm/rev V – 30m/min
015	Turning (finishing)	Toolholder Korloy DWLNR 2525-M 08 with WNMG insert - HA 080404- HA PC 8110	T = 0.8-1 mm, S rev = 0.05-0.15 mm/rev V - 80m/min
020	Turning (rough)	Toolholder Korloy DCLNR A 25 R - DCLNR / L -19 c plate CNMA - 190616 PC 5300	T = 2-3 mm, S rev = 0.2-0.3 mm/rev V - 25m/min
025	Turning (finishing)	Toolholder Korloy DCLNR A 25 R - DCLNR / L -19 c plate CNMG - HA 190608-MM PC 8110	T = 1 mm, S rev = 0.1-0.2 mm/rev V – 70m/min
030	Turning (finishing)	Toolholder Korloy DCLNR A 25 R - DCLNR / L -19 c plate CNMG - HA 190608-MM PC 8110	T = 1 mm, S rev = 0.1-0.2 mm/rev V – 70m/min
035	Milling	cutter Korloy SRES 4120-080-R10, Z=4, D=12	N = 1050 rpm V = 39.5 mm \ min S = 0.052 mm/tooth
040	Drilling	Drill Korloy MSDPH 0100-5S D=10 mm	S = 0.1 – 0.16 mm/rev V = 30 - 40 m/min
045	Threaded	Tap Taegutec TPH652B10 M12x1.75	V = 4 - 6 m/min S =1.75 mm/rev

### **3.3 Machine tools and clamping devices**

Clamping devices are called devices that eliminate the possibility of vibrations or displacement of the workpiece relative to the mounting elements under the action of its own weight and forces arising during processing (assembly). The need to use clamping devices disappears in two cases: when a heavy, stable workpiece (assembly unit) is processed (assembled), compared with the weight of which the processing (assembly) forces are small; when the forces arising during processing (assembly) are applied so that they cannot disturb the position of the workpiece achieved by basing.

The requirements for clamping devices are as follows.

- 1. When clamping, the position of the workpiece achieved by basing should not be moved. This is ensured by a rational choice of the direction and point of application of the clamping force.
- 2. The clamp should not cause deformation of the fixed workpieces or damage (collapse) of their surfaces.
- 3. The clamping force should be the minimum necessary, but sufficient to ensure a reliable position of the workpiece relative to the mounting elements of the fixtures during processing.
- 4. Clamping and detachment of workpieces must be done with a minimum expenditure of effort and time of the worker. When using manual clamps, the hand force must not exceed 147 N.
- 5. Cutting forces should, if possible, not be taken up by clamping devices.
- 6. The clamping device should be simple in design, as convenient and safe as possible in operation.



The fulfillment of most of these requirements is associated with the correct determination of the magnitude, direction and place of application of the clamping forces.

The calculation of the clamping forces can be reduced to solving the problem of statics for the equilibrium of a rigid body (workpiece) under the action of a system of external forces.

On the one hand, the workpiece is subjected to gravity and forces arising during processing, on the other hand, the required clamping forces and support reactions. Under the action of these forces, the workpiece must maintain balance. When calculating, one should be guided by such a stage of the action of shear forces and moments at which the clamping forces are greatest.

Table 3.2 Equipment and cutting tools

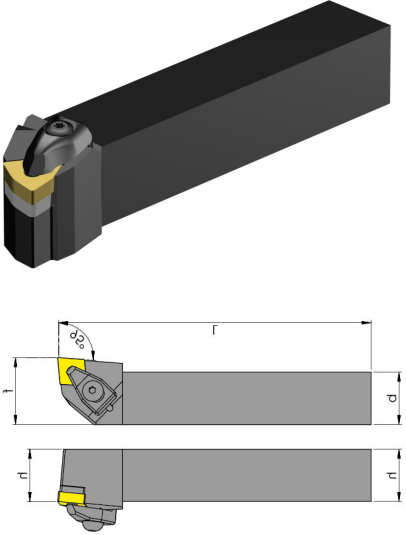
Name of clamping device	Photo of fixture	Photo of the tool
Collet chuck for cutter and drill GARANT 30 5390_25 HSK - A 63 DIN 69893-1. Collets ER #30 8880 – 9434		
Quick change tap chuck 33 4652_ M 3-12 Garant HSK - A 63 DIN 69893		

<p>3-jaw turning chuck for holding the cutter DIN 55026</p>		
<p>Lunette SR 5 for blank support</p>		

### 3.4 Measuring tools

The choice of measuring tools, when checking the accuracy of parts is one of the most important stages in the development of technological processes for technical control.

The basic principles for choosing measuring instruments are as follows: the accuracy of the measuring instrument must be sufficiently high compared to the specified accuracy of the measured size, and the complexity of measurements and their cost should be as low as possible, providing the highest productivity and economy.

Insufficient measurement accuracy leads to the fact that part of the good products are rejected (error of the first kind); at the same time, for the same reason,

another part of actually unusable products is accepted as suitable (error of the second kind).

Excessive measurement accuracy, as a rule, is associated with an excessive increase in the complexity and cost of product quality control, and therefore leads to an increase in the cost of its production.

When choosing measuring instruments and methods for monitoring products, take into account

- permissible error of the measuring device-tool;
- scale division price;
- sensitivity threshold;
- measurement limits, weight, overall dimensions, working load, etc.



The determining factor is the allowable error of the measuring instrument, which follows from the standardized definition of the actual size as well as the size obtained as a result of measurement with an allowable error.

The simplest method for choosing measuring instruments is based on the fact that the accuracy of the measuring instrument must be several times higher than the manufacturing accuracy of the measured part. When controlling the accuracy of technological processes by measuring the accuracy of the dimensions of parts, it is recommended to use measuring instruments with a division value of not more than 1/6 of the manufacturing tolerance.

The value of the permissible measurement error depends on the tolerance, which is associated with the nominal size and with the degree of accuracy of the size of the controlled product. The calculated values of the permissible measurement error in  $\mu\text{m}$  are given in the standard tables [17].

It is recommended that the values of permissible measurement errors for grades 2–9 be up to 30%, for grade 10 and coarser - up to 20% of the product manufacturing tolerance.

Table 3.3. Measuring tool data

Name of the measuring tool	Tool photo	Specifications
Digital calipers MarCal 41 5320 - 750		Discreteness step: 0.01 mm Error (+-): 0.05 mm Surface length for measurement inside dimensions: 20mm Sponge length: 150mm
Micrometer Mitutoyo 42 0500 DIN 863		Graduation: 0.01 mm Micrometer screw diameter: 6.35mm Drum diameter: 18mm
Digital micrometric bore gauge Micromar 42 8930 30-40 DIN 863		Resolution step: 0.001 mm Limits of error: 0.004 mm Depth _ Extension measurements: 76/226

### 3.5 Creating control program in Autodesk FeatureCAM software

This section presents an alternative option of processing for part "Cylinder" using a machine with computer numerical control. We use software Dassault Systèmes SolidWorks to create a 3D model and Autodesk FeatureCAM 19 software to control processing of the part from scratch. The code for the machine control program has also been developed using FeatureCAM.

CNC machine, for one this control code was developed, was a MultiCut 500i with a Siemens Sinumerik 840D SL control system that has 5 continuously controlled axes for machining. Stages for processing can be also seen in Appendix B sketch automation.

Autodesk FeatureCam allows to increase productivity of machines and, at the same time, to reach the highest quality at production of parts.

The purpose is to show an example of one of the possible options for machining using a 5-coordinate machine, as well as increase efficiency and productivity in creating control programs for CNC machines in mass production.

The main advantages of the Feature Cam 2016 package:

- Flexible strategies for roughing and finishing;
- High speed calculation of control programs;
- Automated feed optimization to reduce processing time;
- Integrated processing visualization tools;
- Check and exclude cuts;
- Import of solid-state, surface models, as well as frame geometry in various formats: AutoCAD, STL, STEP, IGES, Parasolid;
- Automatic recognition of typical elements (holes, pockets, pockets, etc.) and their processing;
- Closing holes and grooves to prevent their processing;
- Flexible border mechanism to limit the processing area;
- Generation of debugging maps for control programs.

At the beginning we create a three-dimensional solid-state model of the part and on the basis of the calculated allowances for machining we create a part using the CAD program SolidWorks (Fig. 3.6). The three-dimensional model of a detail serves not only for the best visualization, but also on it in the end carry out comparisons after computer processing. This allows to quickly check the places where the allowance remained, and where there could be cuts and collisions. This reduces the time spent calculating the CNC program.

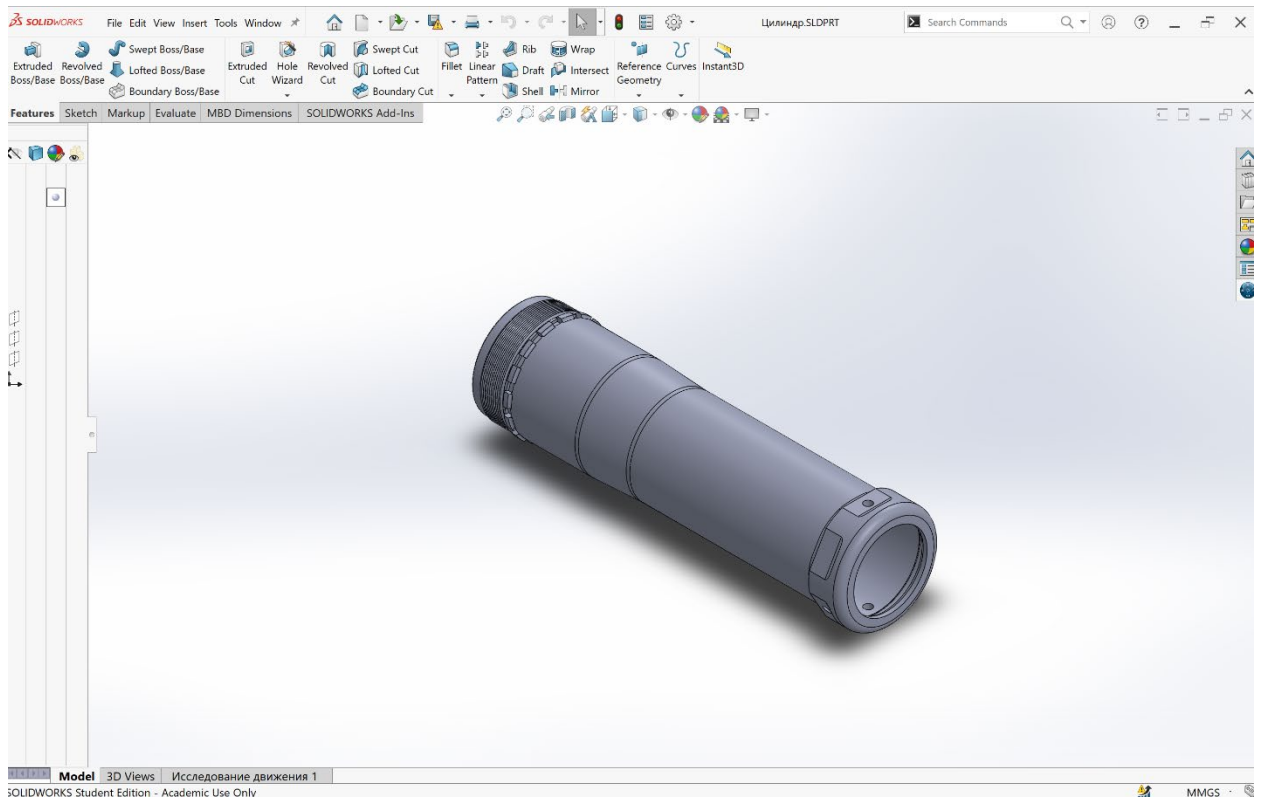

Figure 3.6. 3D model of the part “Cylinder” in SolidWorks

Then we import our model to FeatureCam and start with determining surfaces that must be cut. List of operations created at this step and we configured processes like milling, cutting, drilling. All types of operations like rough and finishing were considered. Software can simulate processing one operation after another with different speed, that can be configured by user, like it happens with real machine. Type of CNC machine and cutting tools can be also chose from software’s database.

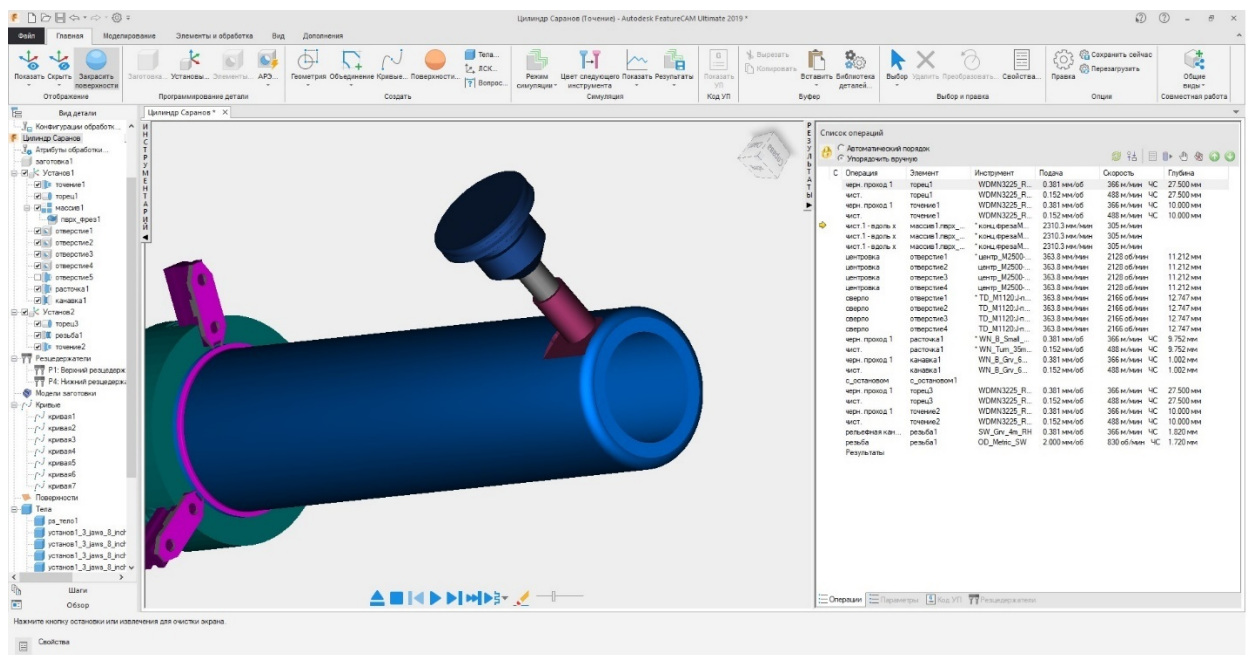

Figure 3.7. Milling flats on a cylinder

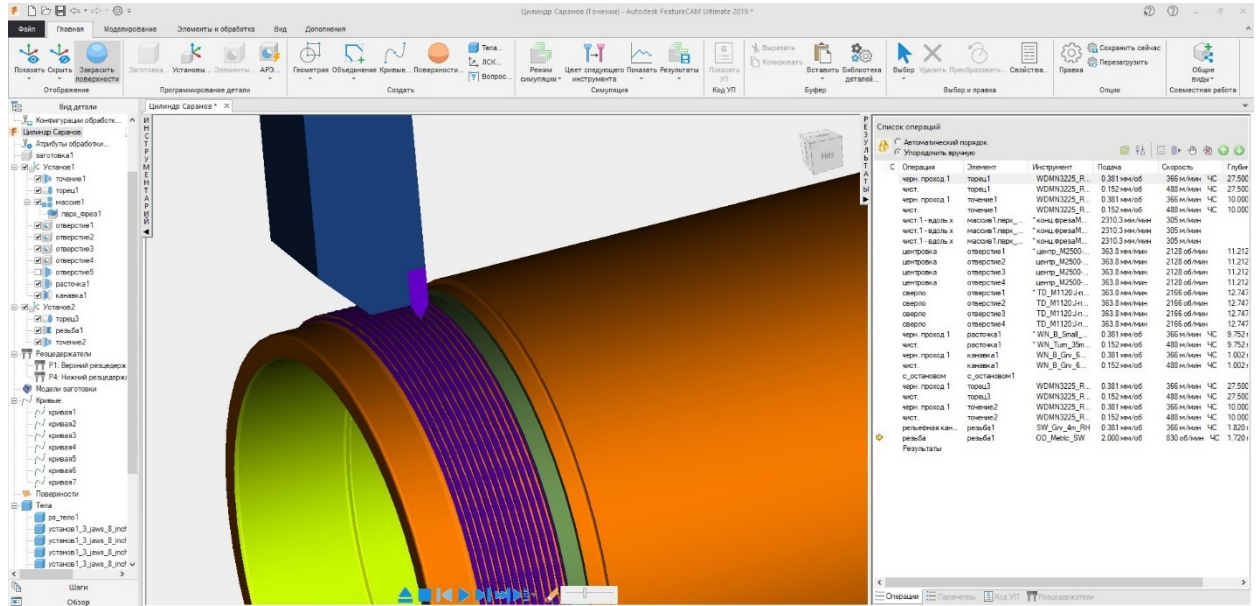

Figure 3.8. External thread formation

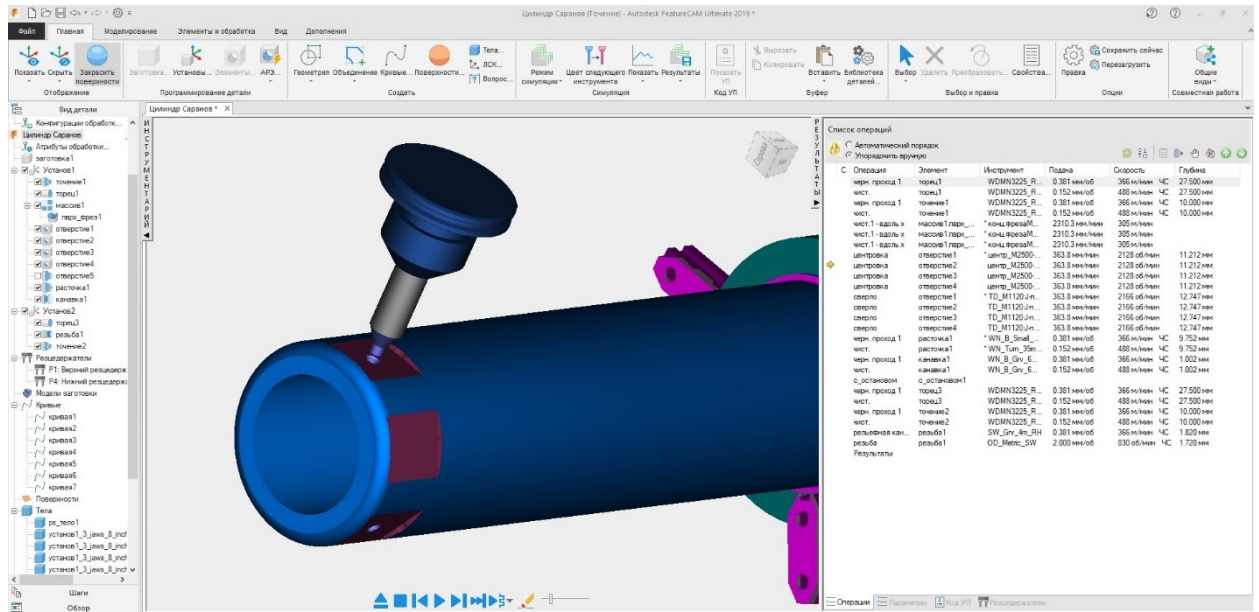

Figure 3.9. Drilling through holes

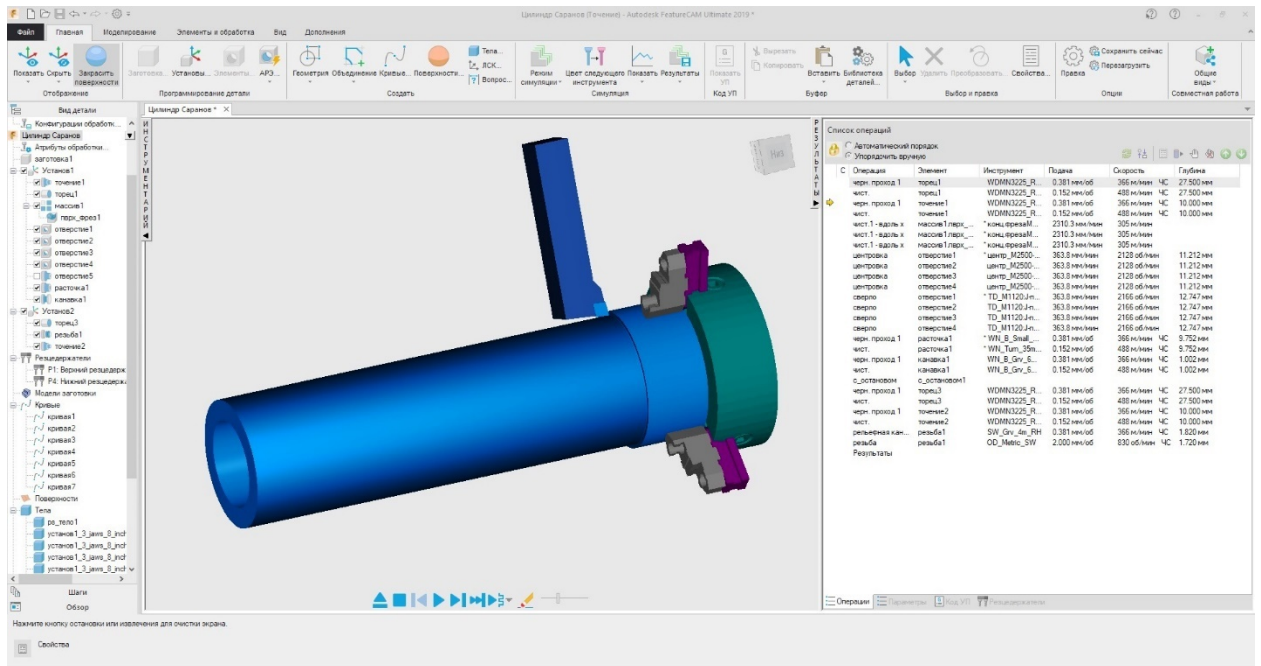

Figure 3.10. External cutting of the part

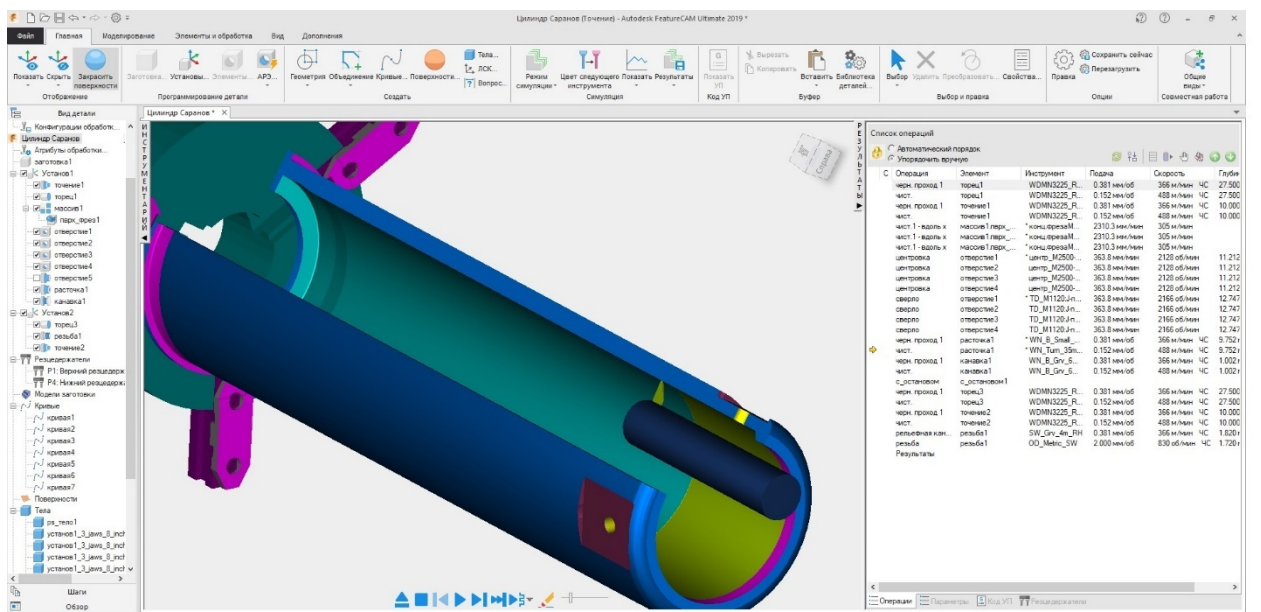

Figure 3.11. Draft and finishing cylinder boring

After complete processing as a result we get not only a graphical display of the result and visualization, but also machine code for the CNC machine, i.e. the control program is generated. A part of this program is presented below:

```

N1          ( OPERATION: ROUGH FACE ТОРЕЦ1 )
G28 V0
G18 G99 M46 ( TURN MODE )
G0 T0101    ( TOOL:01 WDMN3225_RDNMG150604_NC3120 )
G50 S6000
G96 S1200 M3
G0 X6.1811 Z0.0039 M8
G1 X3.7795 F0.015
Z0.0197
X3.8074 Z0.0336
G0 Z0.1181

```

```

( OPERATION: FINISH FACE ТОРЕЦ1 )
G50S6000
G97 S976 M3
G0 X6.2598 Z0.1181 M8
G96 S1600
Z0.
G1 X3.7795 F0.006
X4.0022 Z0.1114

```

```

( OPERATION: ROUGH TURN ТОЧЕНИЕ1 )
G50S6000
G97 S742 M3
G0 X6.1811 Z0.1114 M8
G96 S1200
X6.2598 Z0.1614
X5.6772
G1 Z-20.9055 F0.015
X6.0236
X6.0515 Z-20.8916
G0 Z0.1614
G1 X5.3858
Z-0.1073
G3 X5.6772 Z-0.4331 R0.437
G1 X5.705 Z-0.4192
G0 Z0.1614
G1 X5.0945
Z-0.0211
G3 X5.3858 Z-0.1073 R0.437
G1 X5.4137 Z-0.0934
G0 Z0.1614
G1 X4.8031
Z0.0039
G3 X5.0945 Z-0.0211 R0.437
G1 X5.1223 Z-0.0071
G0 Z0.1181

```

```

( OPERATION: FINISH TURN ТОЧЕНИЕ1 )
G50S6000
G97 S976 M3
G0 X6.2598 Z0.0381 M8
G96 S1600

```

These technical capabilities of programs and equipment today eliminate 90% of the possibility of undesirable product defects at the design stage and the creation of control program for machines, which then has a positive impact on economic efficiency.

## 4 SCIENTIFIC SECTION

### 4.1 Circular economy. Disposal of industrial waste

Waste from mechanical processing of metals.



Figure 4.1. Metal milling. [38]

This is the most common form of scrap metal in the form of shavings, metal dust, and more. This category includes scrap metal generated through the process:

- cutting (turning, milling, drilling; slotting and other types);
- grinding or tumbling;
- cleaning equipment components.

When cutting, the following types of metal waste are encountered:

1. Shavings are the main type of scrap, classified as uncontaminated and containing oil products. The first type includes chips sorted by type of material: cast iron, steel, copper and others; as well as unsorted - separately for ferrous, non-ferrous metals. Wastes contaminated with oil products (less

than and more than 15% separately) or cutting fluid are attributed to contaminated chips.

2. Sawdust. They are classified similarly to chips according to the type of material being processed: cast iron, steel, copper, aluminum, titanium, alloys and others, as well as a mixture of ferrous or non-ferrous metals.
3. Abrasive metal sludge. It is divided into two groups, according to the degree of pollution with oil products: up to and over 15%.
4. Waste stripping devices for electrical discharge machining of steel, with an oil content of less than 15%.

#### *Chips accumulated at the plant*

Separately, the scrap generated in the process of grinding metals is considered.

They can be divided into three categories:

- abrasive dust or powder;
- grinding sludge;
- waste containing metal oxides.

Abrasive dust is formed during manual grinding of ferrous and non-ferrous metals, as well as separately when working on a tumbler. Abrasive powder is divided into 4 types. The first variety contains dust sorted according to the type of non-ferrous metal, with its content of more than 50%. Unsorted powder is a mixture of separately black and non-ferrous, as well as both types of metal at the same time. Ferrous metal dust is additionally classified according to the content of metal particles: up to 50% or more.

During mechanical grinding, a sludge is formed, the composition of which includes:

- metal particles;
- oil products;
- oils;
- cutting fluids.

It should be added that during tumbling, along with dust, there are non-metallic wastes - sawdust, for example.



Figure 4.2. Accumulated chips in the plant [38]

## 4.2 Lubricants and coolants

Research work was carried out on the selection and application of lubricating and cooling technical means (LCTM) for blade processing of workpieces made of titanium alloys.

An increase in processing productivity and an improvement in the quality of parts obtained by cutting provide the functional actions of LCTM and, above all, lubricating, cooling and washing.

The lubricating effect of LCTM during blade cutting of workpieces in the range of practically used modes is manifested in the setting of the contact surfaces of the cutting tool and the workpiece, and the effect of LCTM on build-up formation often predetermines their technological efficiency. At the same time, the tasks of reducing the wear intensity of the cutting tool and achieving the specified parameters

of roughness and dimensional accuracy of machined surfaces often conflict. On the one hand, build-up formation on the working surfaces of the cutting tool provides its “protection” against wear, and on the other hand, it leads to an increase in the height and step parameters of roughness and to a decrease in the stability of ensuring the dimensional accuracy of the machined surfaces of the part or workpiece. Consequently, in order to ensure low height and step roughness parameters and high stability of the dimensional accuracy of parts, built-up formation should be minimized. However, in this case, the wear rate of the cutting tool may increase, which will predetermine a short period of tool life.

The cooling effect of LCTM on different technological operations of blade processing manifests itself in different ways due to the large specifics of heat transfer conditions. An increase in the dimensional accuracy of machined workpieces is ensured by reducing temperature deformations and the tool life of the cutting tool due to lower temperatures and more favorable distribution of them on the contact surfaces.

The efficiency of the cooling effect of the LCTM depends both on its heat capacity and on the ability of the technological system and, above all, the tool-blank-chip system to provide additional heat removal, the amount of which is largely determined by the lubricating effect of LCTM due to heat exchange at the boundaries with LCTM. The greatest influence on the decrease in the temperature of the contact surfaces during blade cutting is exerted by the heat exchange of LC with the surfaces of cutting tools.

On an industrial scale, the production of liquid LCs of two classes (types) has been mastered: oil and water LCs and certain grades of solid and plastic technological lubricants. *Lubricating* fluids are mineral oils with a kinematic viscosity of 2...40 mm<sup>2</sup>/s without additives or with additives for various functional purposes. Possessing good lubricating properties, this class of LCTM has a number of disadvantages: low cooling capacity, increased volatility and fire hazard, and high cost.

Aqueous LCTM may contain mineral oils, emulsifiers, corrosion inhibitors, biocides, antiwear and extreme pressure additives, antifoam additives, electrolytes, binder substances (water, alcohols, etc.) and other organic and inorganic substances. Water-based LCs, compared to oil-based ones, have a higher cooling capacity, fire safety, and less danger to human health. However, they have a number of disadvantages: relatively low lubricating properties; impossibility of application in especially severe conditions of metal processing; the need to address the issues of decomposition and disposal of waste aqueous solutions.

In terms of machinability, titanium alloys are close to corrosion-resistant and heat-resistant steels and alloys. High strength and extremely low values of thermal conductivity and thermal diffusivity (approximately 4–5 times less than that of low-carbon steels) often cause intense heat release in the cutting zone, and, consequently, structural-phase transformations in the surface layer of the material. The processing of workpieces made of titanium alloys is associated with the risk of the formation of tensile residual stresses of the first kind and fatigue cracks.

LCs have a complex and ambiguous effect on the processes occurring during blade processing of workpieces made of titanium alloys (Table 4.1), which depends not only on the cutting conditions, but also on the chemical composition of the structural-phase state of the surface layer of the workpieces, as well as on the amount of LC located in the contact zone during processing.

Table 4.1 - Recommendations for the use of LC in the operations of blade processing of workpieces made of titanium alloys

Technological operation	Brand of water LCTM	Classification - new designation
Turning, boring, cut off	Akvol-2, 3...10% emulsion;	M.A.D.
	Akvol-2E;	M.A.D.
	ARIAN AQOL-2, Aqvol 2E (does not contain chlorine);	M.A.D.
	Aqual-6, 5...20% emulsion;	M.A.D.
	VIPOL-311, -321.351, 3...7 % microemulsion ;	MAE
	Permol ( Rovel Permол-6), 3...10% emulsion ;	M.A.D.
	Progress-13K, 3...5% solution ;	MAN
	RATAK 6210R, 1...10% emulsion;	MAV
	Tekhmol -1, 2...7% solution;	MAN
	Ukrinol-1M, 2...3% emulsion;	MAC
Ukrinol-1M AZMOL.	MAC	
Drilling, countersinking	Akvol-2, 3...10% emulsion;	M.A.D.
	Akvol-2E;	M.A.D.
	ARIAN AQOL-2, Aqvol 2E (does not contain chlorine);	M.A.D.
	Aqual-6, 5...20% emulsion;	M.A.D.
	Permol ( Rovel Permол-6), 3...10% emulsion ;	M.A.D.
	Progress-13K, 3...5% solution ;	MAN
	RATAK 6210R, 1...10% emulsion;	MAV
	Tekhmol -1, 2...7% solution;	MAN
	Ukrinol-1M, 2...3% emulsion;	MAC
	Ukrinol-1M AZMOL.	MAC
Deep drilling	Aqual-6, 5...20% emulsion;	M.A.D.
	Progress-13K, 3...5% solution ;	MAN
	RATAK 6210R, 1...10% emulsion;	MAV
Deployment	Akvol-2, 3...10% emulsion;	M.A.D.
	Akvol-2E;	M.A.D.
	ARIAN AQOL-2, Aqvol 2E (does not contain chlorine);	M.A.D.
	Aqual-6, 5...20% emulsion;	M.A.D.
	VIPOL-311, -321.351, 3...7% micro-emulsion;	MAE

Technological operation	Brand of water LCTM	Classification - new designation
	Permol ( Rovel Permол-6), 3...10% emulsion ; Progress-13K, 3...5% solution ; RATAK 6210R, 1...10% emulsion; Tekhmol -1, 2...7% solution; Ukrinol-1M, 2...3% emulsion;	M.A.D. MAN MAV MAN MAC
thread cutting	Aqual-6, 5...20% emulsion; Progress-13K, 3...5% solution ; RATAK 6210R, 1...10% emulsion; Tekhmol -1, 2...7% solution; Ukrinol-1M, 2...3% emulsion; Ukrinol-1M AZMOL.	M.A.D. MAN MAV MAN MAC MAC
Milling	Akvol-2, 3...10% emulsion; Akvol-2E; ARIAN AQOL-2, Aqvol 2E (does not contain chlorine); Aqual-6, 5...20% emulsion; VIPOL-311, -321.351, 3...7% micro-emulsion; Permол ( Rovel Permол-6), 3...10% emulsion ;	M.A.D. M.A.D. M.A.D. M.A.D. MAE M.A.D.
	Progress-13K, 3...5% solution ; RATAK 6210R, 1...10% emulsion; Tekhmol -1, 2...7% solution; Ukrinol-1M, 2...3% emulsion; Ukrinol-1M AZMOL.	MAN MAV MAN MAC MAC
Slotting , gear cutting	-	
Stretching	Aqual-6, 5...20% emulsion; Progress-13K, 3...5% solution ; RATAK 6210R, 1...10% emulsion; Tekhmol -1, 2...7% solution; Ukrinol-1M, 2...3% emulsion; Ukrinol-1M AZMOL.	M.A.D. MAN MAV MAN MAC MAC

It is often almost impossible to focus on the areas of application of LCTM recommended by manufacturers due to their clearly advertising nature and the desire of developers to ascribe to their compositions a universal character, transferring them to the group of LCTM for mass use. In this regard, there is a need for comparative testing of LCs for technological efficiency in specific conditions of intended use and for work on their unification. Such tests are carried out according

to standard and unified methods using standard documentation for registration of test results for LCTM. This allows enterprises to create their own databanks based on test results, exchange information with other enterprises, increase efficiency and reduce the cost of expensive testing.

Below are the results of comparative technological tests of six aqueous LCs: 3% aqueous emulsion Ukrinol-1M, 5% emulsion Akvol-6, 5% solutions of concentrates of semi-synthetic LCs Vels-1, Permол-6, Tekhmол-1; synthetic LC Suvar-3M, as well as the results of technological tests of the Swiss 7% emulsion Blasocut 4000 CF (without chlorine) and Blasocut 4000 Strong (containing chlorine).

On a test stand equipped with an electromechanical drive for stepless vertical feed, the workpieces were fixed in a universal dynamometer mod. UDM-100. The holes were drilled with spiral drills of the same production batch with a diameter 10 mm of R6M5 high-speed steel with a lead angle of  $118^\circ$  (TU 2-035-600-77) in samples of titanium alloy VT-22. All samples were made from rolled products at the delivery stage (without hardening). Cutting conditions were assigned in accordance with existing standards, taking into account the machinability group of the material. When drilling holes in workpieces made of titanium alloy VT-22 -  $n = 500 \text{ min}^{-1}$ ,  $V_s = 15 \text{ mm/min}$ . The drilling depth in all cases was 60 mm. LCTM was supplied to the cutting zone by irrigation through a regular nozzle at a flow rate of  $45 \text{ dm}^3/\text{min}$ .

As the main indicator of the technological efficiency of LCTM, the tool life period  $\tau_c$  was used, which is determined by the operating time of the drill until the specified maximum wear on the flank surface is reached (0,3 mm). Several other indicators were also used: torque  $M_{cr}$  (N · m), axial component  $P_x$  cutting force (N) and wear rate of the bridge  $a_n$  ( $\mu\text{m/min}$ ). Drill wear was monitored before and after each hole was drilled by direct measurements on an instrumental microscope with a scale interval of 0,001 mm. Each experiment (testing one LC when drilling with one drill) was repeated at least three times, which ensured the reliability of the results obtained with a probability of 0.95.

When machining holes in workpieces made of high-strength titanium alloy VT-22, the emulsion Ukrinol-1M (8.7) min and Blasocut 4000 Strong (8.9 min) was the best among the tested CLs in terms of tool life. The test results of the cutting tool life period are presented in the graph (Fig. 4.3). Somewhat smaller values  $\tau_s$  obtained by drilling with the use of LCTM Akvol-6. COTS Permол-6 and Vels-1 provide the lowest values of  $P_x$ , and LCTM Ukrinol-1M and Akvol-6 provide the minimum value of  $M_{cr}$ .

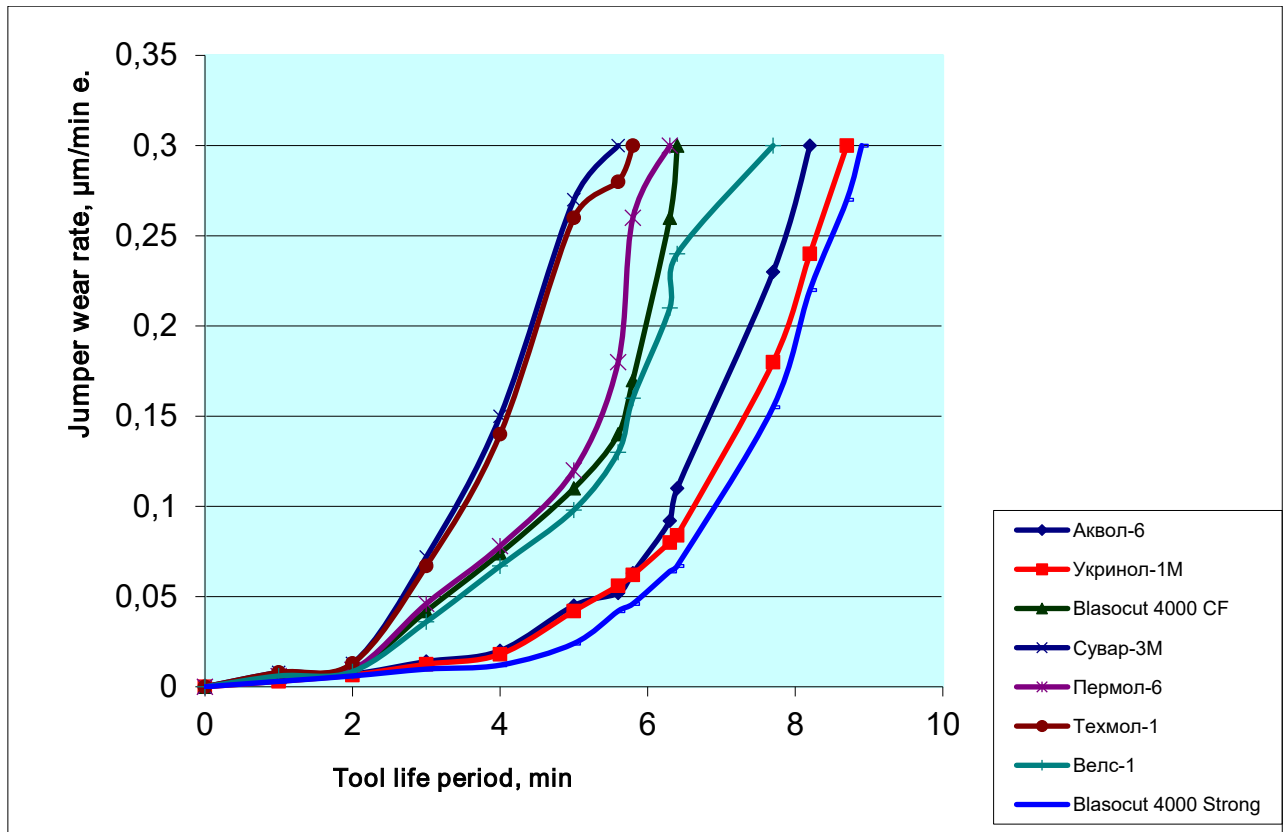

Figure 4.3. Durability period of the cutting tool when machining holes in workpieces made of high-strength titanium alloy VT-22.

Obviously, for practical purposes, the evaluation of the LCTM by one criterion is unacceptable, and by several criteria at the same time it is difficult. A fairly objective assessment can be provided by the rating method. In table. 4.2 and the histogram in Figure 4.4 presents an assessment of the test results when ranking the LC by the most important criteria for the technological efficiency of deep drilling: the period of resistance  $\tau$  from the twist drill, the torque  $M_{kr}$  and the axial component of the cutting force  $P_x$ . LCTM, which showed the lowest technological

efficiency, was evaluated by two points; LCTM, providing the best results in one indicator - 12 points.

Table 4.2 - The results of the rating assessment of LC by the most important criteria for the technological efficiency of drilling holes

Brand LCTM	The total number of points in terms of $\tau_{with}$ , $M_{cr}$ , $P_x$
5% solution Vels- 1	15
5% solution Permол- 6	15
5% emulsion from Akvol -6 emulsol	11
3% emulsion from Ukrinol -1M emulsol	19.5
5% solution of Suvar -3M	-
5% solution Tekhmол -1	10.5

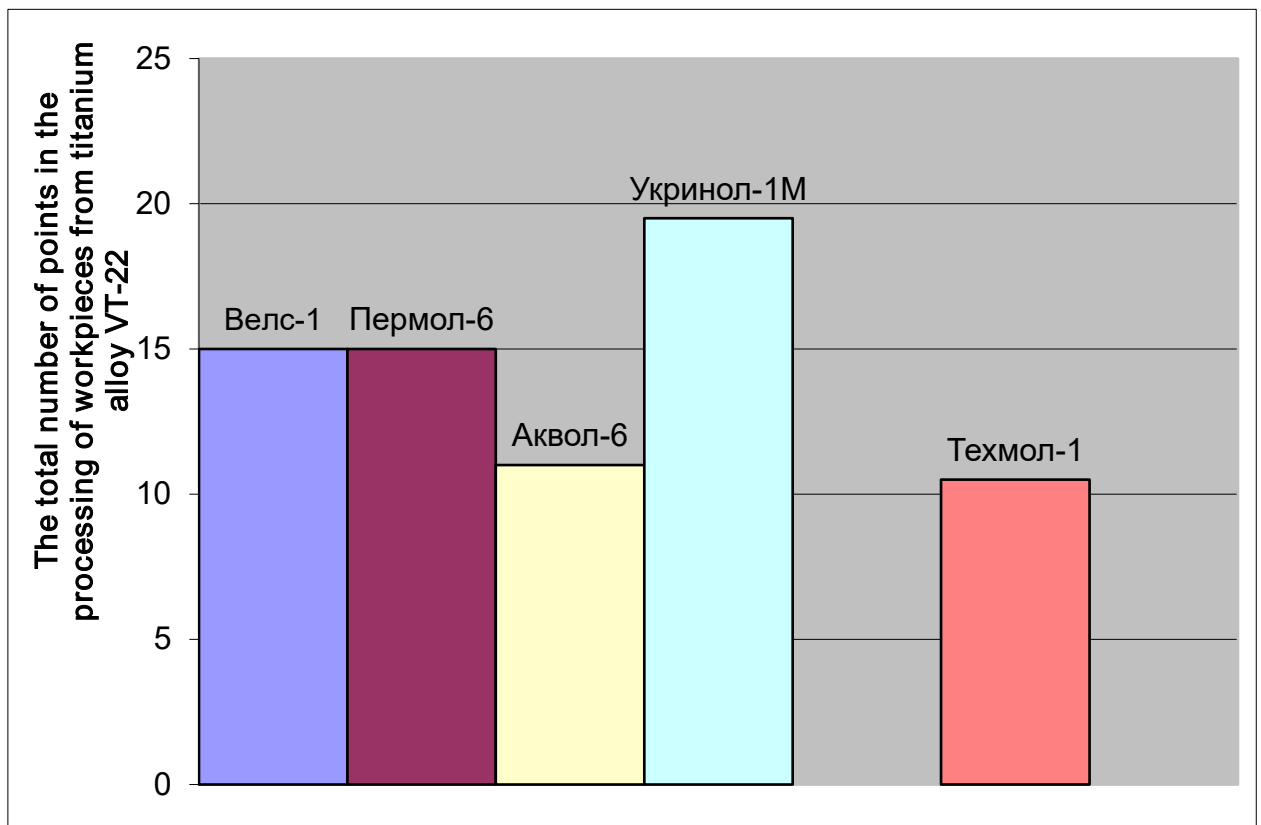

Figure 4.4. Histogram of the results of the LCTM rating assessment according to the most important criteria for the technological efficiency of hole drilling

The rating method for evaluating technological efficiency can be used to select a unified LC when processing workpieces from titanium alloy VT-22 (table 4.3, histogram figure 4.5) manufactured in a workshop or enterprise as a whole.

Table 4.3 - Selection of LC for deep drilling of holes in workpieces made of titanium alloy VT-22.

Brand LCTM	Total processing points
Vels-1	35
Permол-6	26.5
Akvол-6	34
Ukrinol-1M	45
Suvar-3M	-
Tekhmол-1	15.5

When drilling holes in workpieces made of titanium alloy VT-22, the best performance is provided by Ukrinol-1M emulsion. In second place are Permол-6 and Vels-1.

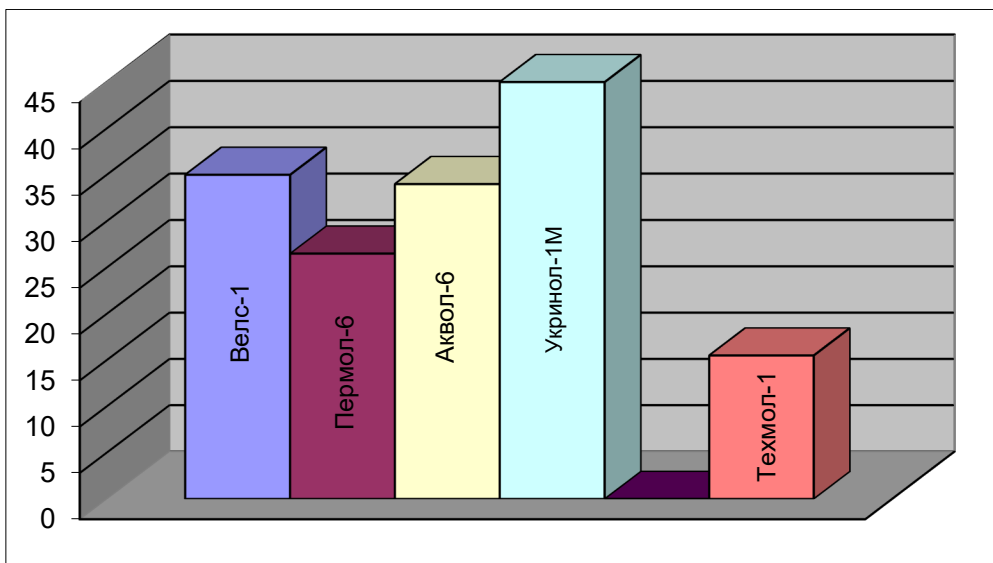

Figure 4.5. Histogram of total points when processing titanium alloy VT-22.

Taking into account the above, the LC for processing workpieces made of titanium alloy VT-22 is chosen based primarily on the physical and mechanical properties of the material of the workpiece being processed and the type of technological operations. This takes into account the change in the physicochemical properties of the materials of the workpiece and tool with an increase in temperature in the contact zones during cutting, as well as a number of factors united by the concept of "processing conditions": the shape, dimensions and design features of the

workpiece; kinematic and dynamic features of the technological operation; the required quality of a part or workpiece (at an intermediate operation); the shape and dimensions of the cutting tool; tool material and type of cutting (free, non-free, intermittent, continuous, rectangular and oblique), the purity of the LC, the method and technique of supplying the LC to the processing zone, etc.

### **4.3 Part life cycle**

Any product, including engineering products, has its own life cycle of active existence until obsolescence and liquidation. Moral obsolescence is the loss of the technical and economic efficiency of using a product as a result of scientific and technological progress and the appearance on the market of more modern samples of a similar purpose. It comes before physical wear and tear, i.e. products can be physically used, but it is no longer economically efficient, and it concerns not a single instance, but a certain type of product. For example, the following have long been morally obsolete and decommissioned: for shipbuilding - steamships; for railway transport - locomotives; in sound reproduction - gramophones, etc. Accordingly, they were successively replaced in whole or in part: for railway transport - diesel locomotives, electric locomotives, high-speed express trains; for shipbuilding - diesel -electric ships, hydrofoils or hovercraft; for sound reproduction - reel and cassette tape recorders, CD players, players on solid crystals. The replacement of the same type of products, as can be seen from the examples given, occurs in cycles.

Thus, we can say that the path of a product as a type begins from the moment the idea is born and the need for it is formed and ends with the processes of moral "withering away", decommissioning with subsequent destruction (utilization). The product type is not just a car, but, for example, a family car, such as a minivan; not just a milling machine, but, for example, gear hobbing, etc. Moreover, each type of product has a set of specific technical characteristics: overall, energy, mass, etc.

It is noted that the processes of the "life" of the product are similar to those occurring in wildlife. They are multilateral and multi-stage, and it is customary to designate them by the concept of "product life cycle" (products). Let's consider this concept.

Life cycle of a machine-building product. Life cycle, as defined by its ISO 9004-1 standard, is a set of processes performed from the moment the needs of society for a particular product are identified to the moment they are met and the product is disposed of.

Most enlarged, the entire life cycle of a machine-building product can be represented as four successive stages:

- • formation of the need for such a product and its development;
- • preparation of its production and manufacture;
- • intended use (operation);
- • liquidation (utilization).

Modern standards such as ISO 9000 describe the life cycle in more detailed stages. Let me briefly describe some of the stages. The beginning of the life cycle is conditionally considered the formation of initial requirements based on the completed marketing research needs for a given class (or type) of products. At this stage, preliminary studies are carried out, pre-design work is carried out, and the terms of reference for development are formed. The desired product exists only in the form of an idea and requirements.

As a rule, the end of the development of a new product coincides with the beginning of the period of technological preparation and development of production. This period is one of the important components of the life cycle, since its reduction allows you to quickly launch the production of a new product and reach consumers earlier. Reducing the preparation time makes it possible to increase the life cycle of a product as a product and thereby obtain an additional economic effect.

At the same time, products of a particular type can simultaneously be at different stages of the life cycle.

For example, aviation factories still produce reliable transport aircraft IL-76, created in the 70s. XX century, some of the copies made at different times are in operation, some are undergoing major repairs, and the oldest machines that have exhausted their resources are destroyed.

In reality, the existence of a product as a product begins after the end of its manufacture, i.e. in practice, its life cycle is limited to the stage of operation (application), including periods of service and maintenance.

### **4.3.1 Product recycling**

The production of rolled metal products and finished products is based on the use of high-quality raw materials. In addition to mining and smelting ore, material can be obtained from scrap metal.

Compliance with the technological process in the processing of scrap metal, the use of modern technologies and equipment makes it possible to obtain high-quality steel with a wide range of uses. According to its characteristics, the material does not differ from the metal obtained by smelting ore. Blanks are used in mechanical engineering and instrument making, production of metal structures, products for various purposes.

Scrap metal recycling is beneficial for the following reasons:

- for the state, the remelting of scrap makes it possible to reduce the consumption of natural resources;
- energy costs and the cost of obtaining steel are reduced;
- the environmental situation is improving, as the amount of harmful emissions is reduced;
- it is possible to process scrap and obtain high-quality raw materials much faster than when mining ore and remelting it.

The economic component is decisive. The volume of scrap processing is increasing every year, technological processes are being improved, new areas of application of recyclables are emerging.

## Stages of scrap metal processing

The prospects for increasing the volume of scrap processing are obvious. For businesses, this approach is becoming increasingly relevant.

The standard technology for processing scrap metal consists of the following steps:

- at the stage of acceptance, primary points weigh scrap metal and make payment;
- sorting involves the distribution of scrap metal by type and profile;
- for ease of transportation and processing, the material is cut into separate fragments;
- purification from impurities is a prerequisite for obtaining high-quality raw materials;
- the final stage is remelting, the resulting rolled metal can be reused.

The best option is to receive scrap with simultaneous sorting. This approach significantly reduces labor costs and speeds up the technological process of processing. Some firms do not always sort scrap with high quality, as a result, metal with impurities enters the remelting.

The full cycle of processing at one enterprise is the best option. The company is engaged in the reception of primary raw materials and supplies customers with finished metal products. The company is interested in obtaining high-quality products, therefore, carefully monitors the observance of technology. The legislation stipulates the requirement for radiation monitoring of scrap. Raw materials are checked at the stage of acceptance, pre-sales preparation and before implementation.

Sorting. A step-by-step approach to scrap processing allows obtaining high quality raw materials. The focus is on the sorting stage. Ferrous and non-ferrous metals should fall into different piles. Other tasks of the enterprise employees at this stage are:

- sorting of scrap metal by overall dimensions;
- separation of scrap by chemical properties;

- exclusion from raw materials of garbage and impurities necessary to obtain high-quality steel.

Automation of the sorting process, despite the high cost of equipment, quickly pays off. This effect is achieved by increasing the sorting speed and eliminating the human factor.

Metal cutting. An obligatory stage of processing is considered cutting and cutting of scrap. Large metal products must be crushed for ease of transportation and processing. For this, powerful scissors and plasma cutting technology are used. There are technical requirements for the size of the blanks that must be met.

The use of powerful presses allows compacting small parts into rectangular bars. Due to the high pressure of the working mechanisms, the bars are reduced in size, while their density increases. After packaging, the blanks are sent for further processing.

Scrap metal cleaning. At the next stage, the bars are sent to a special chamber and subjected to the process of crushing into small fractions. The technology allows you to remove dirt, debris, dust, non-metallic elements. A special separator delivers a high-pressure air jet. Metal elements remain in the chamber, and all debris is blown out.

A magnetic separator is also actively used. When crushed raw materials pass through the belt, the magnet attracts metal elements. Non-magnetic fractions are dumped into the accumulator.

Remelting. Sorted and crushed raw materials are melted down in special furnaces. Next, the metal enters mechanical or hydraulic installations, where it is pressed into briquettes. This form is also determined by the convenience of transportation, storage and use.

Furnaces for scrap processing can be plasma or electric. Equipment of the first type is cheaper, but have a lower efficiency. Electric models are more productive, but the level of safety for personnel is lower.

The use of secondary metal. Secondary raw materials are actively purchased by companies producing wire and metal containers. Raw materials are also in

demand in the manufacture of metal structures in construction, for use in mechanical engineering.

Scrap blanks are used by enterprises manufacturing rolled metal products, hardware, end products from different steel grades. Recycled steel and ore steel are almost identical in their characteristics, so the restrictions on the use of scrap blanks are minimal.

Equipment for the processing of scrap metal. The large dimensions and volume of recycled materials determine the size of the workshops. The enterprises use powerful, load-lifting mechanisms, truck cranes and other systems. The following types of equipment are used for sorting, grinding and remelting:

- batchers and loaders, with the help of which raw materials are moved for further processing;
- crushing equipment, grinders and separators separate the metal into small fractions;
- for the cutting, such devices as hydraulic shears, gas cutting equipment, press machines are used;
- special chambers and presses make it possible to obtain compact packages of scrap suitable for further processing;
- with the help of alligator scissors, pipes, fittings, reinforced wires are cut into the desired size.

For enterprises involved in the processing of scrap in large volumes, the best option is to purchase a mini-factory. The technical capabilities of such a set make it possible to remelt any scrap, the volume of raw materials produced can reach 1 million tons or more per year.

Problems in the processing of scrap metal. Despite the cost-effectiveness of existing technology, scrap metal processing has its own challenges. The main problem is considered to be a large amount of waste. When using gas cutting torches, sunk losses reach 3-5 percent. The use of more advanced technologies reduces the amount of waste, but the equipment is much more expensive.

Sorting of scrap metal involves the allocation of large areas. Accordingly, reception points and sorting shops should have an appropriate area and height. The remaining problems are minor and do not affect the growth in the popularity of recycling. The benefits of scrap remelting far outweigh the disadvantages and challenges.

#### **4.3.2 Features of melting titanium alloys**

When heated in air, titanium interacts with all gases. The interaction of solid titanium with oxygen is accompanied by the formation of  $\text{TiO}_2$ ,  $\text{Ti}_2\text{O}_3$ , and  $\text{TiO}$  oxides. As the temperature rises, oxygen diffuses into the metal, forming interstitial solid solutions. Liquid titanium dissolves oxygen. During crystallization, titanium with oxygen forms a series of solid solutions. Oxygen stabilizes the  $\alpha$ -phase by raising the temperature of the polymorphic transformation of  $\alpha$ -Ti to  $\beta$ -Ti. With an increase in the oxygen content, technological plasticity deteriorates, impact strength, relative elongation and narrowing drop sharply, strength and hardness increase. Within the limits of up to 0.2% (by mass), each hundredth of a percent of oxygen increases the tensile strength by 12.3 MPa, hardness by 39 MPa and reduces the relative elongation and narrowing by 1-1.2%. [31] Nitrogen also forms interstitial solutions with titanium, stabilizes the  $\alpha$ -phase and strengthens it. Each hundredth of a percent of nitrogen increases the tensile strength of titanium by 19.6 MPa and hardness by 59 MPa. At a content of 0.2% nitrogen, titanium becomes brittle.

The dissolution of oxygen and nitrogen in titanium is an irreversible process. The solubility of hydrogen in titanium (up to 400  $\text{cm}^3/\text{g}$ ) is four orders of magnitude higher than in aluminum. As the temperature increases, the solubility decreases. Hydrogen stabilizes the  $\beta$ -phase, lowering the temperature of the polymorphic transformation. Being present in the form of titanium hydride  $\text{TiH}_2$ , hydrogen

sharply reduces plastic characteristics, especially impact strength. Hydrogen is one of the most harmful titanium impurities.

Carbon with titanium forms a stable TiC carbide, increases the temperature of its polymorphic transformation, and in the region of low concentrations, each hundredth of a percent of carbon increases the tensile strength by 7 MPa and hardness by 19 MPa.

Titanium actively interacts with water vapor, carbon monoxide and dioxide, hydrocarbons and other gases. The result of the interaction is the enrichment of the melt with oxygen, hydrogen, carbon.

Along with gases, titanium interacts with all refractory materials, reducing oxides and dissolving carbon. The high chemical activity necessitates the melting of titanium and alloys based on it in a vacuum or an atmosphere of inert gases - argon and helium. In the practice of domestic plants, vacuum melting is mainly used at a residual pressure in the furnace of 1.33–0.13 Pa.

For the manufacture of shaped castings, melting is carried out in arc skull furnaces with a consumable electrode in graphite crucibles at a current density of 10-30 A cm<sup>2</sup>. For the manufacture of crucibles, dense grades of electrode graphite are used. Saturation of alloys with carbon is prevented by freezing on the inner surface of the crucibles a layer of metal 50-60 mm thick at the bottom and 12-16 mm along the walls. Ingots of the first remelting with a diameter of 170-300 mm and a length of 500 mm are used as a consumable electrode. When smelting alloys in the charge, up to 30% of large-sized wastes of own production (profits, risers, reject castings) that have been cleaned in tumbling drums are used. Waste is loaded to the bottom of the crucible prior to melting. Melting mode: current strength 14 35 kA; voltage 30-50 V; alloy deposition rate 0.7–1.34 kg/kWh (8–15 kg/min), arc length 60–80 mm. The melt is stirred with a solenoid.

In the process of melting, titanium waste is 0.1-0.2%, aluminum 2.0-2.5%, manganese 10-15%. The total losses during the second remelting are 0.3–0.6%. The residual concentration of hydrogen during vacuum melting is reduced to 0.002-0.003% (by weight).

Similar melting regimes are prescribed in the production of ingots in DTV furnaces. The charge materials for the production of ingots from titanium alloys are titanium sponge, alloying elements in the form of pure metals and ligatures, waste products of our own production. Titanium sponge is a porous gray metal mass with a size of pieces from 2 to 70 mm in diameter.

The sponge is stored and transported in special containers with a hermetic seal.

Consumable electrodes are made from charge materials for melting. In pure form, aluminum, chromium, copper, manganese, vanadium, zirconium, iron, and silicon are introduced into the charge. Molybdenum and tin are introduced in the form of ligatures with aluminum. All fragile charge materials are crushed in crushers into pieces no larger than 15 mm in diameter, and then sieved through a sieve with a mesh size of 2x2 mm. The fine fraction, in order to avoid its loss, is introduced when pressing the consumable electrode wrapped in a soft aluminum tape. For critical purpose ingots, the crushed ligature is subjected to magnetic separation. Aluminum and aluminum ligature - tin is crushed into shavings on planing machines; aluminum is also used in the form of finely cut pieces of wire.

Waste titanium alloys are cleaned before being used in the charge. Lumpy waste is tumbled to remove oxides and pickled to remove the gas-saturated layer (1-1.5 mm). The chips are subjected to crushing and magnetic separation to separate cutting tool fragments.

Two methods of manufacturing consumable electrodes are used - sintering and pressing. The essence of the sintering method is that the sponge and alloying components are fed into the electric arc zone of a vacuum electric arc furnace with a non- consumable electrode. The charge is partially melted. Liquid metal contributes to the formation of a large number of contacts between individual pieces of sponge, which leads to a sufficiently strong electrode. As the sintering progresses, the charge is gradually loaded, while simultaneously lifting the graphite electrode. The sintering method makes it possible to produce a compact electrode of the required length. The main disadvantages of the sintering method are low

productivity, graphite contamination, and uneven distribution of alloying elements. In the practice of domestic factories for the manufacture of consumable electrodes, the pressing method is used. Fir is pressed in most cases on vertical or horizontal hydraulic presses into a continuous conical matrix with a specific pressing pressure of 250-300 MPa. To obtain ingots of the necessary uniformity in composition, a portion of the charge per one pressing is taken equal to 5–15 kg. The mass of the portion should not exceed half the mass of the liquid bath during the first remelting.

In some cases, to improve electron emission and ensure the stability of the electric arc, 0.02-0.45% Mg is introduced into the electrode material. The rapid evaporation of magnesium during melting contributes to the ionization of the interelectrode space, which creates good conditions for arc burning. Evaporating magnesium condenses on the cold parts of the furnace without contaminating the melt.

Practice has established that in order to obtain a high-quality surface of the ingot and ensure stable arcing, the electrode diameter should be close to the size of the ingot. So, for example, for an ingot with a diameter of 300 mm, electrodes with a diameter of 220 mm are used, for an ingot with a diameter of 500 mm, electrodes with a diameter of 420 mm are used.

Melting with a consumable electrode is carried out in the following sequence. All parts of the furnace in contact with metal are cleaned of contaminants. A pressed electrode is introduced inside the mold from below, paying particular attention to the accuracy of centering the electrode. Then the tray is tightly attached to the mold, a vacuum of 1.33 Pa is created, the water-cooling system is turned on, and the electrode is welded to the tip of the electrode holder. To do this, an arc is ignited between the electrode and the electrode holder. Within 10-15 s, a pool of liquid metal is formed at the upper end of the electrode, into which, after the current is turned off, the tip of the electrode holder is quickly lowered. After 10-15 minutes of exposure, the tray is lowered, a layer of sponge is poured on it and put back in place. In the furnace, the same vacuum is created as when welding the electrode, they are checked for leakage, the current is turned on, and by lowering the electrode until it comes

into contact with the sponge lying on the tray, the arc is ignited. As it melts, the electrode goes down. Due to the release of a large number of volatiles, the arc is unstable. The regulation of the arc length during the melting of the pressed electrode is performed automatically. Stir the melt with a solenoid. Depending on the diameter of the consumable electrode, a current of 4.8–7 kA and a voltage of 26–30 V is used for melting. The melting rate in this case varies between 2.5–4.0 kg/min. After melting the consumable electrode, the resulting ingot is cooled in the mold to 400–500°C. To accelerate cooling, helium is supplied to the working space of the furnace. The ingot of the first heat, due to its heterogeneity in chemical composition, is used as a consumable electrode in the second heat.

Hot ingots of the first remelting immediately after unloading from the mold are cleaned with a metal brush in running water to remove chlorides. Then, crowns are cut off on lathes and oxidized places are turned. If it is necessary to obtain large castings, several ingots of the first melt are welded into one electrode using a technology similar to welding a pressed electrode to the tip of an electrode holder.

Before melting, a titanium template is placed on the tray, which prevents the tray from burning when the arc is ignited. The second remelting is carried out at a direct current of 6.6–11 kA and a voltage of 26–30 V. The deposition rate in this melting mode is 3.5–5.5 kg/min. The arc is adjusted automatically. To reduce the size of the shrinkage cavity, the upper part of the ingot of the second remelting is heated for 30–40 min. The ingots are cooled in the mold for 1.5–2 hours and then removed from the furnace.

In most cases, the first and second remelting is carried out in different furnaces. This mode of operation is associated with a large expenditure of time for cooling the ingots of the first heat and for creating the necessary vacuum.

#### **4.4 Alternative materials for part production**

Aircraft landing gear are among those elements that must withstand very heavy loads, so there are very high requirements for their manufacture.

It is impossible to say that such chassis are made of only one material. Indeed, in aircraft, one of the main factors is the insignificant weight of structures, therefore, in the manufacture of the chassis, several materials are used at once, and these are steel, titanium and various composites.

What titanium is good for is its lightness, strength, and high temperature resistance. Steel, of course, is also not a compound of iron with one carbon; magnesium and other additives are also used there.

Titanium and its alloys are increasingly being used in the aerospace and biomedical fields, which exploit its unique properties. However, machining titanium also presents unique challenges faced by engineers accustomed to machining other metals. Here we look at why machining titanium is so difficult and look at the various techniques that can be used to get the best results when machining titanium.

While aluminum and aluminum alloys were previously the materials of choice in the aerospace industry, titanium and titanium alloys are increasingly being used in new aircraft designs. These materials are also used in the biomedical industry. The reasons for their popularity include light weight, high strength, excellent fatigue performance and high resistance to aggressive environments, no rust and failure. Titanium parts last longer, provide better performance and results than parts made from other metals and materials [34].

In general, the landing gear of an aircraft, like all its other components, belongs to complex structures. For these reasons, it is not possible to replace the material for the manufacture of this critical part of the Cylinder aircraft chassis with alternative materials such as wood, plastic, glass, carbon fiber and other composites. A possible option is to use aviation aluminum, but it will still not be possible to achieve such characteristics and properties as when using titanium. It will be inferior in strength and performance.

The aircraft landing gear is a highly loaded unit that operates at large temperature ranges. During takeoff and landing of an aircraft, the temperature difference can reach tens of degrees. This node is also affected by many different

forces. When an aircraft lands, it bears the weight of the aircraft, the cargo carried, taking into account the overloads from landing.

#### 4.4.1 Prospects and problems of using titanium alloys

The widespread use of titanium alloys in aircraft and rocket construction began in the mid-1960s. the last century. This was caused, as has been repeatedly pointed out, by their high specific strength in a fairly wide temperature range (parts made of titanium alloys are used in the temperature range from -253 to +600°C) and unique corrosion resistance in a wide variety of media. The first industrial structural titanium alloys (VT5, VT5-1, OT4, VT6) had a strength level of 700-950 MPa. In modern aircraft industry, alloys are used, the strength level of which can reach 1300 MPa. These are new generation alloys VT23M, VT32, VT43, VT22M, VT22I. This level of strength is achieved not only by creating new compositions, but also by developing new technological processes of deformation and heat treatment. In this case, the entire variety of application conditions is ensured by a wide range of alloys with an appropriate set of properties.

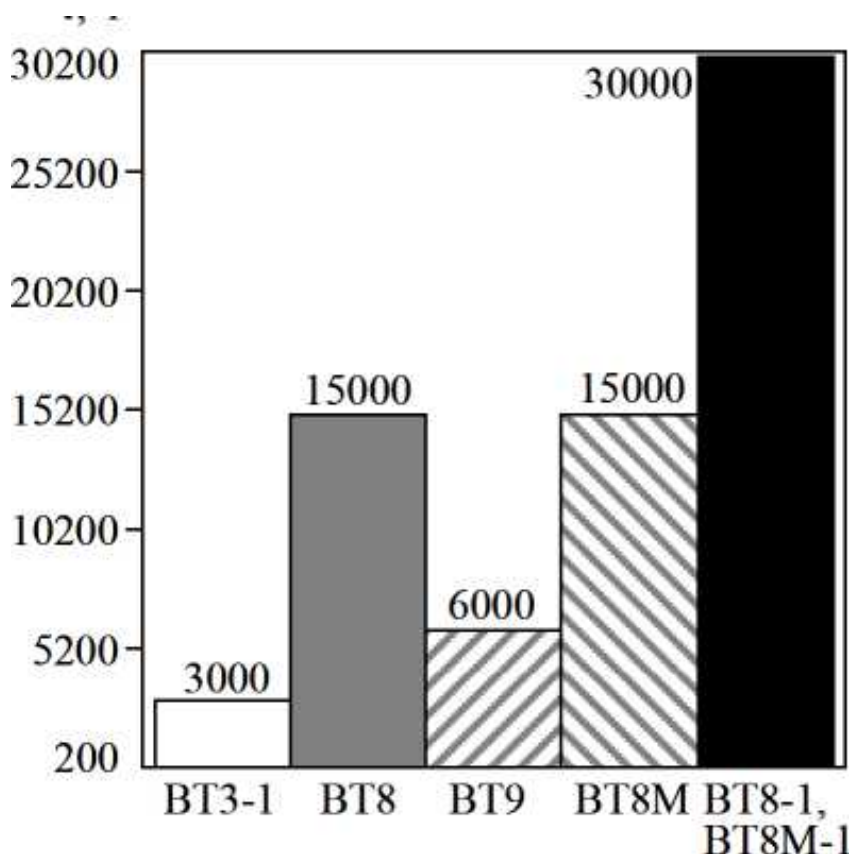

Figure 4.6. Service life of heat-resistant titanium alloys at 450°C [31]

Along with titanium-based structural alloys, high-temperature titanium alloys have also undergone major progressive changes. Their service life in a modern engine reaches 30,000 hours at an operating temperature of 450°C (Fig. 4.6).

In connection with a significant increase in the proportion of titanium alloys in the airframe of modern aircraft, there is a need to develop alloys that are characterized by a high level of strength and rigidity, combined with high ductility at the stage of manufacturing thin sheet blanks. These requirements can be met by alloys based on the P-phase (P- or pseudo-P-alloys.). When quenched, these alloys are extremely ductile and easily deformed to a considerable extent. At the same time, the subsequent low-temperature aging (450-550°C) leads to an increase in the level of their strength properties up to about  $\sigma_{in} = 1400-1500$  MPa. An example of such alloys is the 8R700 alloy and the VT32 alloy.

The alloy has high ductility in the annealed state, which makes it possible to manufacture thin shells of wide-chord blades by sheet stamping. The subsequent process of high temperature soldering of shells made of this alloy, carried out in argon vacuum furnaces, can be combined with the process of thermal hardening.

The appearance of engines of the fifth and sixth generations, in which the temperature and power parameters are significantly superior to those currently existing, leads to the creation of new heat-resistant materials based on titanium with a wider temperature range of application and increased resource characteristics. It is known that heat-resistant titanium alloys created to date can only work successfully up to temperatures of 770-600°C. The limitation in operating temperatures is due to the fact that at temperatures of 600-630°C, the mechanism of titanium oxidation changes. In compressors of modern aircraft engines of foreign companies, titanium alloys T162428, 1M1829, 1M1834 are used for operation in the hot part, it is planned to use the alloy T11100. The service life of these alloys at these temperatures reaches 700 hours. At the same time, its increase is also limited by problems of thermal stability.

Another important aspect in the development of titanium metallurgy is the creation of composite materials based on titanium. In the past few years, the role of composite materials in the design of aircraft has increased dramatically, since they can dramatically increase the weight return of the airframe. Such materials have low density, high rigidity and specific strength. They can be used as noise- absorbing panels, as they increase acoustic endurance by more than 3 times compared to metal materials, as well as airframe load-bearing elements due to increased vibration strength, vibration stiffness and high crack resistance.

All of the above requirements can be met not so much by the creation of new chemical compositions of alloys as by the development of new technological processes such as extrusion, isothermal forging, shaped casting, etc. shaping by 20-30% and obtain an accurate workpiece with a uniform microstructure throughout the volume of the workpiece. The use of shaped casting reduces the cost of parts production by ~2-2.5 times.

It should be noted that the production of titanium sponge and semi-finished products from titanium alloys is in itself a sign of high technology. Only four countries in the world produced such products. These include: USA, England, Japan and Russia. Now China is rapidly progressing in this direction. However, in addition to the problems associated with the creation of a new generation of titanium alloys, materials based on them and the development of advanced technological processes for the production of parts and semi-finished products, there are also problems caused by the changing political and economic situation.

#### **4.4.2 Equipment for processing titanium alloys**

Difficulties in processing titanium products. In fact, everything is somewhat more complicated than it seems at first glance. This metal is characterized by reduced thermal conductivity, is able to bully and stick. In addition, the difficulty lies in the fact that titanium is extremely strong and capable of soldering with a cutting tool during thermal work (after all, the cutter also consists of metal and

almost always turns out to be softer than the workpiece). As a result, the tool wears out particularly quickly and requires constant replacement.

Speaking of metal processing, professionals mean several different types of work with titanium parts. They have their own secrets to neutralize the negative properties of this metal or minimize them. For example, special coolants can help reduce metal picking or sticking, as well as reduce the amount of heat generated when cutting titanium.

Titanium sheets are cut using guillotine shears. Rolled bar metal of large diameter is usually cut with special saws of a mechanical type. This tool is different in that the tooth of the blade is quite large. If the bar has a smaller diameter, a lathe can be used. By the way, the turning of this metal is carried out with cutters made of especially strong alloys. But even under this circumstance, the speed of work must be reduced and is usually inferior to the speed that is observed when machining stainless steel.

Milling titanium parts also causes difficulties: metal begins to stick to the milling teeth. To avoid this, it is necessary to use a cutter made of high hardness alloys. As coolants, liquids are used, the level of viscosity of which is increased.

Special attention should be paid to drilling titanium elements. Chips can accumulate in the grooves, as a result of which the drill begins to deform. Titanium can be drilled with steel high-speed tools.

Titanium can also be used as a material for the components of any structures. Parts made of this metal need to be joined, and several methods are used here. It is worth considering this issue in more detail.

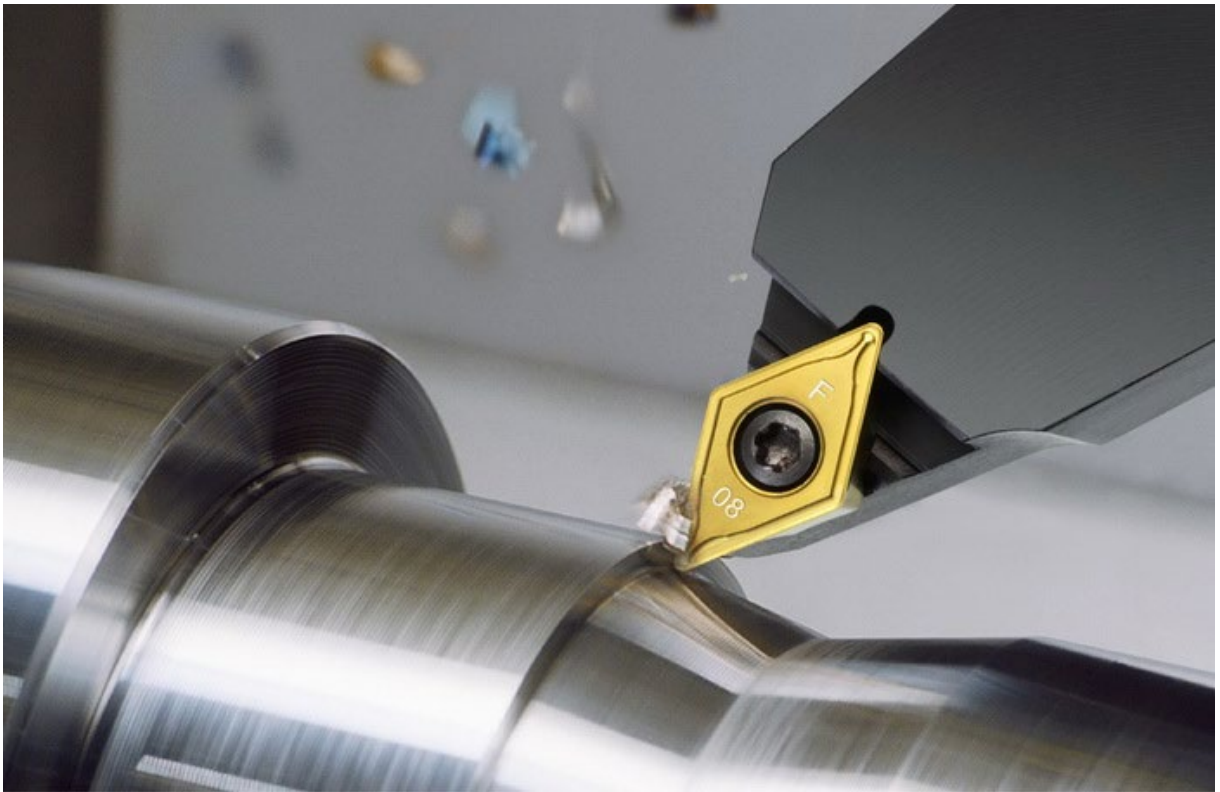

Figure 4.7. Cutting titanium [38]

Ways to neutralize the minuses of titanium. The disadvantage of this unique metal is scuffing, sticking, which occurs during friction. The result is accelerated wear of the titanium alloy. If metal milling is used, this circumstance cannot be ignored. Sliding on a metal surface, titanium reacts and begins to stick, gradually absorbing the entire part.

However, the top layer of titanium can be made more durable, resistant to abrasion and sticking. In particular, nitriding is used for this purpose. The method consists in keeping the part in nitrogen gas. The product must be heated to an average of 900 degrees, and the exposure time is more than a day. As a result of nitriding, the surface of the element is covered with a nitride film, which gives titanium a special hardness. As a result, the wear resistance of the titanium part is increased.

Another method to improve the properties of a metal is its oxidation. It helps eliminate sagging. The titanium part must be heated so that an oxide film forms on its surface. It tightly covers the top layer of metal, not letting air inside.

Oxidation can be low- and high-temperature. In the latter case, the product is kept for several hours in a heated state, and then lowered into cold water. This helps to eliminate scale. The part oxidized in this way becomes more resistant to wear by several orders of magnitude at once.

Milling titanium parts. Titanium is used in a wide variety of industries, including aircraft and astronautics. In these industries, parts made of titanium are most often used.

It should be borne in mind that metal milling is complex. Therefore, for such work, it is required to use sharp cutters with increased speed. It is also necessary to reduce the contact of the part with the cutter as much as possible. Milling starts in an arc, and at the end of the work, the chamfer must be removed at a certain angle.

The qualification of a miller plays a serious role not only in the performance of the work itself, but also in determining their cost. Much will also depend on how complex the geometry of the element created from titanium looks.

## **4.5 Environmental protection**

### **4.5.1 Overview of environmental protection activities in enterprises associated with the processing and operation of metal products**

Environmental protection activities at metalworking enterprises include active and passive methods. Passive methods of environmental protection consist in the rational placement of pollution sources, localization of pollution (isolation and sealing of emission sources, screening of noise and electromagnetic pollution) and purification of emissions into the environment by various methods. Active methods of habitat protection consist in the improvement of existing and the development of new technological processes that prevent the ingress of pollution into the environment, among which the best is the development of waste-free metalworking industries. But at this stage of development of metalworking, passive methods are more applicable, as well as the implementation of environmental education, the

formation of the correct environmental consciousness of each employee in this industry. The prevention of environmental pollution by wastewater is implemented by various methods, including through recycling water supply, which is increasingly being introduced into the practice of the production activities of metalworking enterprises. For a greater effect of environmental protection activities in this industry, it is necessary to solve a number of problems, consisting in reducing the specific costs of water consumption; creation of drainless wastewater treatment systems; preventing the ingress of technologically valuable substances into wastewater. It is necessary to develop and implement methods for the regeneration of cutting fluids (coolants); reagentless methods of processing and regeneration of electrolytes containing nitric, hydrochloric, sulfuric, phosphoric and hydrofluoric acids; methods of dehydration, regeneration and disposal of sludge resulting from wastewater treatment; reagentless removal of oil products from wastewater, etc. The recycling of various wastes is of great importance in the environmental protection activities of the industry. The main waste of metalworking is scrap metal and metal shavings, in which 96% of the total amount is ferrous metals, and the rest is non-ferrous. It has also been established that only 70% of the total amount of processed metal is included in the finished product. Metal waste is disposed of either without remelting or with remelting. Disposal without remelting is economically more profitable, since it does not require energy costs, but not all metal waste can be disposed of in this way. Utilization without remelting is subject to 10-15% of the total amount of scrap metal. Recycling with remelting requires energy, but this method is universal, as it can be used to recycle metal products of any size. Metal shavings and sawdust are subjected to crushing and briquetting to create compact masses by cold or hot briquetting. Chip briquettes help to reduce the melting time and waste of metal in the production of various steels. Scrap metal of complex composition (cars, etc.) is processed using cryogenic technology, in which metal parts are easily separated from non-metal ones. A difficult problem is the separation of metal chips from cutting fluids (coolants), the content of the latter in the chips reaches 20%. To separate the metal from the coolant, heating, centrifugation and

other methods are used. An important task is the disposal of solid organic waste, although they do not make up a large part of solid industrial waste by weight. So, a variety of wood waste is possible. Apply to obtain technological chips and wood-based panels. Cleaning cloth can be reused after washing. Up to 85% of plastics (thermoplastic) can be separated and recovered under elevated temperatures and pressures.

#### **4.5.2 Protection of the air and water basin at the enterprise from pollution**

Mechanical processing of metals on machine tools in workshops is accompanied by the release of dust, oil mist and emulsions, which are ejected from the premises through the ventilation system.

The main measures to protect the atmosphere from pollution by industrial dusts and fogs include the widespread use of dust and mist trapping devices and systems. Based on the modern classification of dust collecting systems, based on the fundamental features of the cleaning process, dust cleaning equipment can be divided into four groups: dry dust collectors, wet dust collectors, electrostatic precipitators and filters.

Dry dust collectors include all devices in which the separation of particles of impurities from the air flow occurs mechanically due to the forces of gravity, inertia, Coriolis. Structurally, dry dust collectors are divided into cyclones, rotary, vortex, radial, louvered dust collectors, etc.

Wet gas cleaning devices are widely used, as they are characterized by high cleaning efficiency from fine dust with a particle diameter of 0.3-1.0 microns, as well as the ability to clean dust from hot and explosive gases. Wet scrubbers operate on the principle of depositing dust particles either on the surface of liquid droplets or on the surface of a liquid film. The sedimentation of dust particles on the liquid occurs under the action of inertia forces and Brownian motion.

Electric cleaning of gases. It is based on the ionization by an electric charge under the influence of a direct electric current (voltage up to 90 kV) of solid and liquid particles suspended in gases, followed by their deposition on the electrodes.

Filtration is widely used in industry for fine cleaning of ventilation air from impurities, as well as for industrial and sanitary cleaning of gas emissions. With this method of gas cleaning, gas flows pass through porous filter membranes that allow gas to pass through but retain solid particles. Filters are used to capture very fine dust fractions (less than 1 micron) and are characterized by high efficiency in gas purification.

Fibrous filters are used to purify the air from mists of acids, alkalis, oils and other liquids, the principle of which is based on the deposition of drops on the surface of the pores, followed by the flow of the liquid under the action of gravity. Deposition of liquid droplets on the surface of the pores occurs under the action of all previously considered mechanisms for separating pollutant particles from the gas phase on the filter elements.

The processes of cleaning technological and ventilation emissions from machine-building enterprises from gas and vaporous impurities are characterized by a number of features: firstly, gases emitted into the atmosphere have a sufficiently high temperature and contain a large amount of dust, which significantly complicates the gas cleaning process and requires preliminary preparation of exhaust gases; secondly, the concentration of gaseous and vaporous impurities, more often in ventilation and less often in technological emissions, is usually variable and very low. Methods for cleaning industrial emissions from gaseous impurities are divided into four groups according to the nature of the course of physical and chemical processes: flushing emissions with solvents of impurities (absorption method); flushing of emissions with solutions of reagents that chemically bind impurities (chemisorption method); absorption of gaseous impurities by solid active substances (adsorption method); adsorption of impurities by applying catalytic conversion.

Protection of the water basin. Three types of wastewater are generated on the territory of industrial enterprises: domestic, surface and industrial. Wastewater from

engineering enterprises may contain the following types of impurities: mechanical impurities of organic and mineral origin, including metal hydroxides; persistent and volatile oil products; emulsions stabilized with various additives; dissolved toxic compounds of organic and inorganic origin (metal ions, phenols, cyanides, sulfates, sulfides, etc.).

In the workshops of mechanical processing, metal processing, water is used for tool cooling, for washing parts and for processing rooms, while wastewater is polluted with mineral oils, soaps, metal and abrasive dust and emulsifiers.

Protection of the water basin is carried out in the following areas: wastewater treatment from mechanical impurities, wastewater treatment from oil-containing impurities, wastewater treatment from metals and their salts, wastewater neutralization, control of wastewater composition.

In accordance with modern requirements, industrial effluents must be pre-treated at local treatment facilities before being discharged into the city sewer, into water bodies or onto the terrain. The purpose of using local treatment facilities is to prepare and treat industrial wastewater for discharge to general factory or city sewer systems or for reuse in production (circulating water supply).

Purification of industrial waste water is to reduce the concentration of fats, oil products, oils and suspended solids.

Purification of wastewater from solid particles, depending on their properties, concentration and fractional composition at machine-building enterprises, is carried out by filtering, settling, separating solid particles in the field of centrifugal forces and filtering. Straining - the primary stage of wastewater treatment - is designed to separate large insoluble particles up to 25 mm in size from wastewater, as well as smaller fibrous contaminants, which, in the process of further processing of wastewater, interfere with the normal operation of the treatment equipment. Straining is carried out by passing water through grates and fiber traps.

Settling is based on the features of the process of sedimentation of solid particles in a liquid. In this case, free settling of non-coalescing particles that have

retained their shapes and sizes, and settling of particles prone to coagulation and changing their shape and sizes, can take place.

The separation of solid impurities in the field of action of centrifugal forces is carried out in open or pressure hydrocyclones and centrifuges.

Wastewater filtration is designed to remove finely dispersed solid impurities with a small concentration. The filtration process is also used after physicochemical and biological purification methods, since some of these methods are accompanied by the release of mechanical impurities into the purified liquid.

Purification of industrial wastewater by pressure flotation. To carry out the purification of industrial wastewater from oil products, oils, suspended solids and other water-insoluble contaminants, treatment facilities are designed and built on the basis of pressure reagent -free flotation units of the “AF” type (flotation apparatus).

The technology of industrial wastewater treatment at AF-type plants provides for:

- air saturation of polluted industrial wastewater under pressure;
- an active process of air desorption with the formation of microbubbles due to a sharp drop in pressure;
- floating of the aggregates formed in this case and the formation of foam (oil sludge) on the surface of the flotation tank;
- removal of the sludge formed during the flotation process into the sludge tank.

Biological treatment of industrial wastewater is a method of industrial wastewater treatment, in which mineralization (extraction) of organic substances by saprobiont microorganisms occurs. It is based on the biochemical decomposition of organic substances by aerobic bacteria, as well as the reduction in the number of pathogens in water to the limits established by sanitary and hygienic requirements.

## 4.6 Disposal of metal waste

Utilization of metals and their processing is the most useful process for the economic life of the country. Metal waste is remelted and can be successfully used further for the manufacture of various products.

These include:

- metal products and appliances that are already out of use;
- waste generated in the production of ferrous metals;
- waste from rolled metal products;
- waste generated when the life of a machine, building, mechanism, metal structure, etc. ends.

Metal waste consists of ferrous and non-ferrous metals, they are explosive, chemical, radioactive and fire hazardous. Like any other waste, metal waste is harmful to the environment. Therefore, the collection and disposal of metal waste must be timely, complete and of high quality.

Recycling of metal waste consists of several technological operations, including:

- dismantling of structures and collection of metal waste;
- transportation of waste to a processing plant;
- verification of metal waste (including dosimetric);
- separation of ferrous metal waste from non-ferrous metal waste;
- separation of various non-metallic impurities;
- final waste control;
- processing.

After that, the waste is converted into finished raw materials or salable metal scrap, ready to be used for metal smelting.

The procurement and processing of scrap metal, as stages in the recycling of secondary metals, are also of great economic importance. There is a direct relationship between the required reserves of resources, the standard of living of the population and the technologies currently used for processing waste. Metal

specialists have long come to the conclusion that the amount of primary natural resources needed for the production of metals is limited. Therefore, obtaining secondary materials from metal waste is a real necessity for the further development of the economy.

Metal waste (scrap metal and metal shavings) is the main type of waste from mechanical engineering and metalworking. At the same time, about 96% of all waste is ferrous metals and only 4% is non-ferrous. There are two ways to dispose of metal waste: without remelting and with remelting. Recycling without remelting involves the re-cutting of sheet metal in order to manufacture small and medium-sized parts from larger waste. Recycling of metal waste with remelting is the main way of their disposal. The smelting of secondary metals from depreciated scrap is the largest area of solid waste consumption in industry (1 ton of iron or steel scrap can save the national economy 3.5 tons of minerals: 2 tons of iron ore, 1 ton of coke and 0.5 tons of limestone).

Using secondary raw materials as a new resource base, recycling is one of the most dynamically developing industries in the world. In countries where environmental protection is of great importance, the volume of recycling of secondary resources is constantly increasing.

To date, the world has accumulated considerable experience in the field of recycling of metal waste, especially in the field of separating metals from other materials and creating processing equipment. Raw materials such as metals can retain their valuable properties for many years and be recycled many times without losing these properties. Proceeding from this, the activity associated with the recycling of metals is one of the most profitable and necessary for society. In addition, scrap metal recycling and its further use as secondary material resources helps to protect the environment, saves energy and conserves natural resources, reducing the load on mineral deposits.

#### **4.6.2 Mitigation of environmental impact.**

Surface treatment increases the service life and improves the appearance of metal products. Individual products are subjected to multiple and varied surface treatments (for example, a car body can be phosphated, primed and painted). This subsection discusses the processes used for surface treatment and methods for reducing their environmental impact.

Minimizing the environmental impact of a metal finishing business requires cooperation between management, employees, local communities and government. The society is interested in the problems of combating long-term pollution of air, water and soil. An effective system of measures for the protection and rational use of the environment cannot be created without detailed knowledge of the specific impacts of all elements, chemicals, metals, and technological processes.

Pollution prevention planning shifts the focus from a simple response of alarm to anticipation of solutions aimed at replacing chemicals, improving technological processes, and introducing a closed production cycle. Such planning implies the following sequence:

1. Take measures to prevent contamination in all production areas.
2. Define waste streams.
3. Set priorities for activities.
4. Identify the root cause of the waste.
5. Identify and implement changes to reduce or prevent waste.
6. Evaluate the results.

Continuous improvement is achieved by setting new priorities and repeating actions that gradually move closer to the goal.

Detailed technical documentation will make it possible to assess the totality of waste, to establish the order of measures for their possible reduction. Competent decisions about potential changes will contribute to:

- real improvement of the production process
- process changes affecting customers and suppliers

- transition to less harmful technological operations, where possible
- reuse, recycling of materials where fundamental changes are not appropriate
- disposal of hazardous waste only as a last resort.

#### Basic and Standard Manufacturing Processes

Cleaning is necessary because all metal finishing processes require finished parts to be free from organic and inorganic contaminants (including oils, scale, grinding and polishing pastes). Three main types of cleaners are used - solvents, degreasing vapors and alkaline detergents [47].

### 4.6.3 Reducing the environmental footprint

The expansion of production volumes, the creation of new technologies in the metalworking industry implies an increase in the volume of processing of raw materials and, as a result, an increase in emissions of dust and various gaseous substances into the atmosphere.

With an increase in production volumes and, accordingly, an increase in pollution, in excess of the assimilation capacity of the environment, external costs arise that are imposed on society [40].

The theory of economic efficiency assumes that the polluter (enterprise, firm, state, etc.) must fully compensate for the environmental damage caused by their activities. This creates incentives to reduce pollution damage at least to the point where the marginal cost of pollution abatement for the producer is equal to the marginal damage caused by that pollution.

Consider the problem of finding the economic optimum of pollution. This concept does not mean that there should be no pollution at all, and they are all neutralized. Unfortunately, in economic reality this is impossible, since the more pollution is captured, the more expensive it is to fight each subsequent unit of pollution. Thus, for the complete elimination of pollution, enormous costs will be required and it will be easier to produce nothing at all. We should talk about certain conditions under which an economic optimum is achieved between production

efficiency and external costs, environmental damage. The growth of the metalworking industry is growing every year.

## CONCLUSIONS AND SUGGESTIONS FOR THE PROJECT

The equipment for machining the "Cylinder" part was determined and selected. A high-performance CNC multifunctional center was used and auxiliary devices were selected. Selected from the manufacturer's catalog suitable cutters, milling cutters, drills, etc.

In the scientific section, the problems of waste disposal in production were considered. Difficulties in the processing of titanium products and features of the smelting of blanks from this material. The possibility of replacing the material of a part for a given aircraft assembly has been studied. The problem of environmental pollution from metalworking production has been studied in more detail. Options for reducing the negative consequences for flora and fauna that may occur during such types of production are considered. An analysis of the life cycle of a titanium alloy part has been carried out.

As a result of the analysis of existing technical processes, the following conclusions can be drawn:

- For the manufacture of a cylinder, it is rational to use a forging blank on horizontal forging machines which will significantly increase the material utilization rate, as well as reduce the number of operations and reduce the labor intensity of manufacturing parts.

In the example of a cylinder, there is no need to drill a hole, which increases the utilization of the material. When manufacturing a part, use pneumatic devices (turning chucks), while reducing the cost of manufacturing special equipment.

- Introduce the replacement of the LCTM brand with Blasocut 4000 Strong, which shows the best results in the processing of titanium alloys.

- When manufacturing a cylinder part, it is necessary to combine two milling and drilling operations into one milling and drilling operation performed from one installation.

- Use the principle of maximum concentration of operations in one workplace.

When carrying out a dimensional analysis, the possibility of ensuring the minimum allowances and the maximum possible tolerances for processing at a given level of product quality was revealed.

We know that the presented project allows to raise labor productivity and product quality to a higher level. Significantly save technological and machine time for the production of our product due to the modern CNC system on the machine, as well as the use of special AutoDesk software FeatureCAM. This project can be implemented at the basic machine-building enterprise, where modern CNC machines are used.

## REFERENCES

1. Guidelines for the implementation of the course project in the discipline "Technology of mechanical engineering" / I.S. Tsekhmistro , NMetAU, 1984
2. Guidelines for the implementation of course work on the discipline "Design of mechanical assembly shops" (for students of the specialty 0501-technology of mechanical engineering, metal-cutting machines and tools). Dnepropetrovsk, DMETI, 1985.
3. Reference technologist-machine builder. In 2 volumes, V.1. Under. Ed. A.G. Kosilova and R.K. Meshcheryakova, 1986.
4. Reference technologist-machine builder. In 2 volumes, V.2. Under. Ed. A.G. Kosilova and R.K. Meshcheryakova, 1986.
5. Rudenko P.A. Design of technological processes in mechanical engineering, High school, 1985. - 250 p.
6. Guidelines for dimensional analysis of technological processes for processing parts in the course and graduation projects (for specialty 1201 - engineering technology). Dnepropetrovsk, DMETI , 1989.
7. Textbook for the course "Fundamentals of engineering technology" / Pod. Ed. I.S., NMetAU , 2000.
8. Egorov M.E. etc. Engineering technology. Higher school, 1976.
9. Guidelines for the performance of tests in the discipline "Fundamentals of mechanical engineering technology" (for students of specialty 1201 - mechanical engineering technology). Dnepropetrovsk, DMETI, 1989.
11. Guidelines. Typical technological processes for processing parts in automated areas and CNC machines. Moscow, NPO ORGSTANKINPROM, 1978 г.
12. Goroshkin A.K. Directory of fixtures for machine tools. Mechanical engineering, 1979.
13. Cutting modes of metals. Directory. Yu.V. Baranovsky , L.A. Brakhman , L.A. Bykov and others - Mechanical engineering, 1972.
14. General engineering standards for time and cutting conditions for the regulation of work performed on universal and multi -purpose machines with numerical control: in 2 volumes - Mechanical engineering, 1990.
15. Guidelines for the implementation of the course work on the discipline "Design of special technological equipment". A.G. Yasev , G.I. Dubovoy - Dnepropetrovsk : NMetAU ,2001 г
16. Korsakov V.S. Fundamentals of fixture design: A textbook for universities - Mechanical engineering, 1983 г.
17. Goroshkin A.K. Devices for metal-cutting machine tools, 1962.

18. G.N.Melnikov , V.P.Voronenko Design of mechanical assembly shops, 1990.
19. P.G. Semenikhin . Choice of rational surface roughness of machine parts, 1964. - 101 p.
20. Physical and Mathematical Theory of Processes of Materials Processing and Engineering Technology / Ed. ed. F.V. Novikov and A.V. Yakimov . In ten volumes. - V.4 "Theory of abrasive and diamond-abrasive processing of materials" - Odessa: ONPU, 2002. - 802 p.
21. Guidelines for the development of the economic part of the diploma project (for students of technical specialties) R. V. Ilyina , V. A. Emelyanov . - Dnepropetrovsk: GmetAU, 1998.
22. Economics of business development: Educational material. / J.M.Petrovich , I.O.Budishcheva , I.G.Ustinov and others ; for red. Y.M. Petrovich . - 2nd ver., Rev. I add . - K .: T-vo "Knowledge", KOO, 2001.
23. Sanitary standards for the design of industrial enterprises. CH 245-71, 1972.
24. GOST 12.1.005-88 SSBT General sanitary and hygienic requirements for the air of the working area. Publishing house of standards, 1988, 75 p.
25. Sn 3228-85 Sanitary norms for permissible noise levels at workplaces. Ministry of Health of the USSR, 1986, 15 p.
26. GOST 12.0.003-83 SSBT. MFM. General safety requirements. Publishing house of standards, 1984, 10 p.
27. GOST 12.1. 012-78 SSBT. Vibration. General safety requirements. Publishing House of Standards, 1978.
28. SNiP II -4-79 Design standards. Natural and artificial lighting, 1980, 48 p.
29. SNiP 2.09.04-87 Administrative and domestic buildings, 1989, 15 p.
30. SNiP 2.01.02-85 Fire regulations, 1986, 206 p.
31. Features of melting titanium alloys 2015. Accessed 20 June 2022. Available at <https://metal-archive.ru/liteynoe-proizvodstvo/1160-osobennosti-plavki-titanovyh-splavov.html>
32. Titanium alloys for engine building, N.A. Overnight.
33. Hard Part Machining, Wit Grzesik 2008.
34. Study Contribution of Surface Quality Parts Machined by Turning Using Hard Materials Razika Aouad, Idriss Amara 2017.
35. Research on Image Processing of Graduated Cylinder Automatic Calibration Device Based on Machine Vision Technology Wen Wang, Ying Fan and others 2022.
36. CNC Machine Technologies: A Review, Sushil Kumar Tripathi 2021.
37. CNC Machine Tools, Xun Xu 2009.

38. Development of technological processes in mechanical engineering A. Pogonin, I. Shrubchenko, A. Afanas'ev 2021.
39. 3D CAD/CAM System, Hao Tang, Yong Li 2021.
40. Environmental Impact, S. Matemilola, H. A. Alabi 2020.
41. Examining the role of cutting fluids in machining and efforts to address associated environmental/health concern, Adler, D.P.H., Adler, W.W.-S., Michalek, D.J. and Sutherland, J.W. 2006.
42. Comparison of Life Cycle Emissions and Energy Consumption for Environmentally Adapted Metalworking Fluid Systems, Iarens, A.F., Zimmerman, J.B., Hayes, K.F., Keoleian, G.A. and Skerlos, S.J. 2007.
43. Industrial Ecology of the Automobile: A Life Cycle Perspective, Keoleian, G.A., Kar, K., Manion, M.M. and Bulkley, J.W. 1997.
44. Waste and Resource Management W.R. Stahel 2017.
45. WIT Transact Ecol Environment E.C. Rada 2013.
46. Cycles Waste Management S. ElSaid, E.H. Aghezzaf, E.H. J Mater 2018.
47. Assessing the environmental impact of metal production processes, T.E. Norgate, S. Jahanshahi, W.J. Rankin 2006.
48. The role of LCA in performance assessment in minerals processing e a copper case study. Environmental issues and management of waste in energy and mineral production. Giurco D, Stewart M, Petrie J. 2000.
49. Alternative routes to stainless steel e a life cycle approach, Norgate TE, Jahanshahi S, Rankin WJ 2004.
50. MULTICUT Line 500i / 630 Multi-tasking turning milling machining center. Accessed 8 June 2022. Available at [www.kovosvit.cz](http://www.kovosvit.cz)



Copied														
Inter.														
Signed														
													31	2
Developed	Saranov N.I.			<b>NTU "DP"</b>	<b>TMM.131-ONPM-22.06</b>									
Checked	Derbaba V.A.													
Accepted	Protsiv V.V.													
T. contr.	Protsiv V.V.			<b>Cylinder</b>										
N. contr.	Protsiv V.V.													
Name of the operation				Material	Hardness	EV	MD	Sizes and dimensions			MOZ	COID		
<b>Control</b>				Alloy VT22 OST 1 90266-86	$\sigma_B = 1078...1274$	kg	7.0	Ø146x530			26,19	010		
Equipment, CNC machine				Designation of the program	To	Tv	T p.z.	T pc.	Coolant					
				-										
P					PI	D or B	L	t	i	S	n	V	T in	T o
01	1. Checking the blank with a steeloscope 100%.													
02														
03	2. Check the actual dimensions of the blank.													
04														
05														
06														
07														
08														
09														
10														
11														
OC														



Copied														
Inter.														
Signed								Chn.	Shts.	No. doc.	Signature	Date		
												31	4	
Developed	Saranov N.I.													
Checked	Derbaba V.A.					NTU "DP"	TMM.131-ONPM-22.06							
Accepted	Protsiv V.V.													
T. contr.	Protsiv V.V.													
N. contr	Protsiv V.V.													020

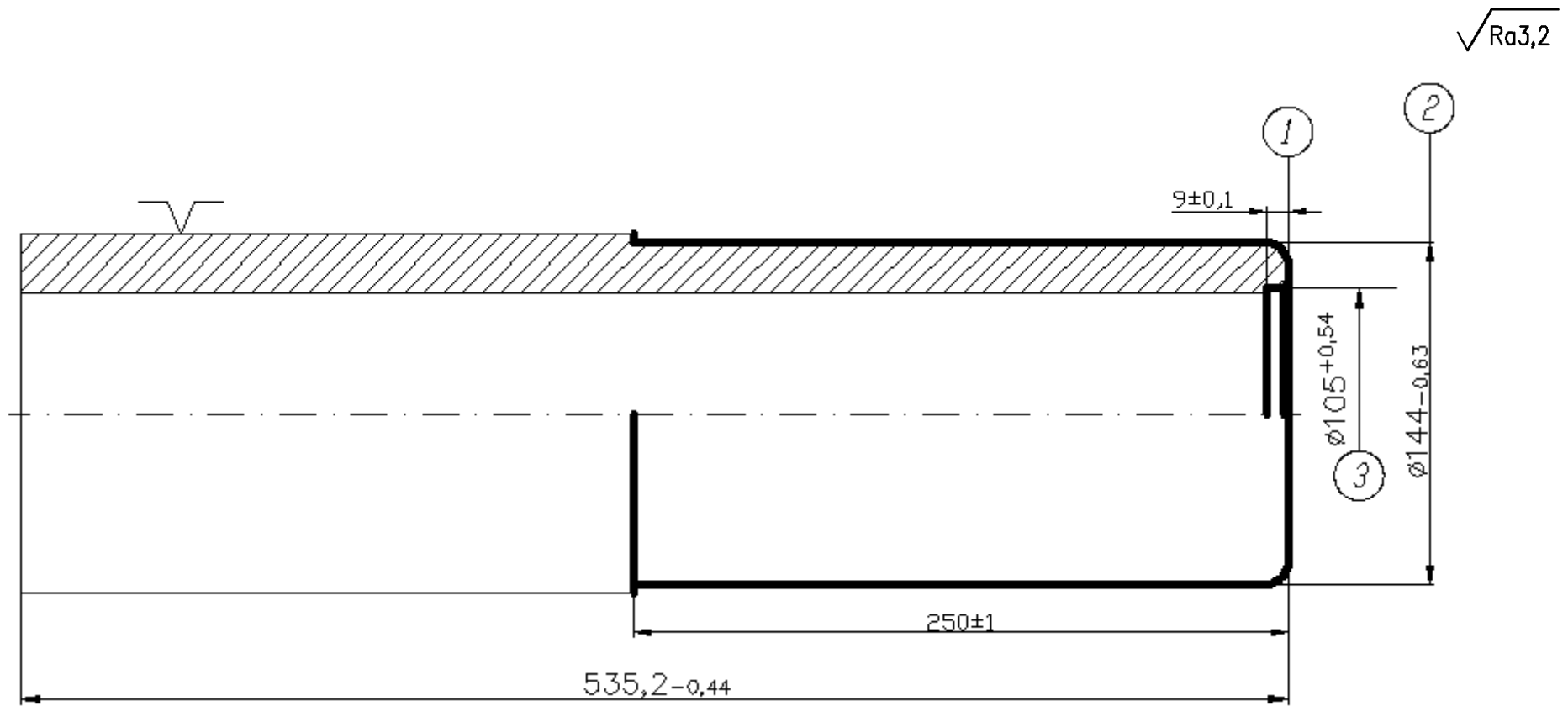



Copied														
Inter.														
Signed								Chn.	Shts.	No. doc.	Signature	Date		
												31	6	
Developed	Saranov N.I.													
Checked	Derbaba V.A.													
Accepted	Protsiv V.V.													
T. contr.	Protsiv V.V.													
N. contr	Protsiv V.V.													025
					<b>NTU "DP"</b>		<b>TMM.131-ONPM-22.06</b>							
<b>Cylinder</b>														

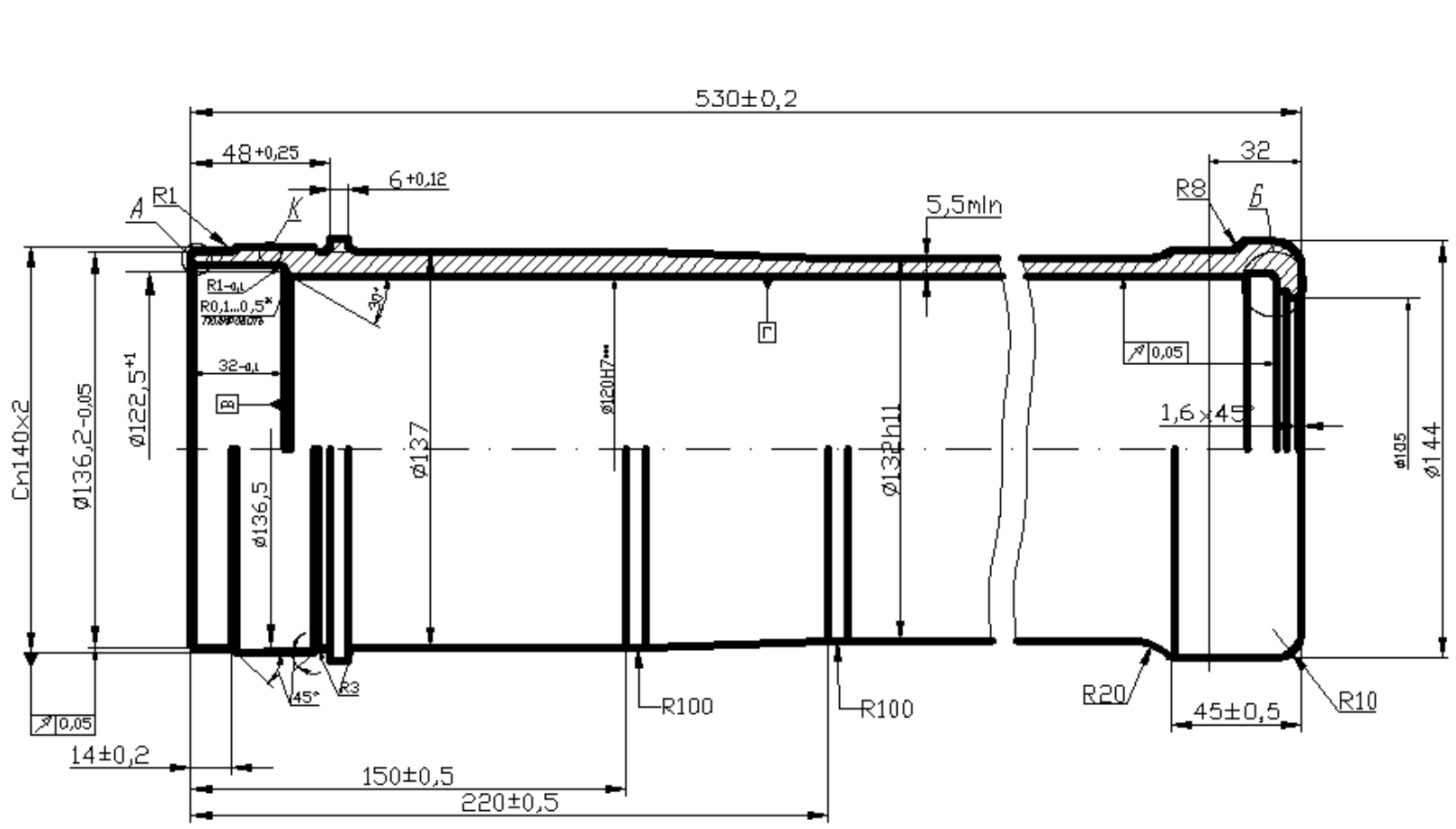

Copied														
Inter.														
Signed								Chn.	Shts.	No. doc.	Signature	Date		
											31	7		
Developed	Saranov N.I.				<b>NTU "DP"</b>	<b>TMM.131-ONPM-22.06</b>		<b>Cylinder</b>						
Checked	Derbaba V.A.													
Accepted	Protsiv V.V.													
T. contr.	Protsiv V.V.													
N. contr	Protsiv V.V.													
													025	

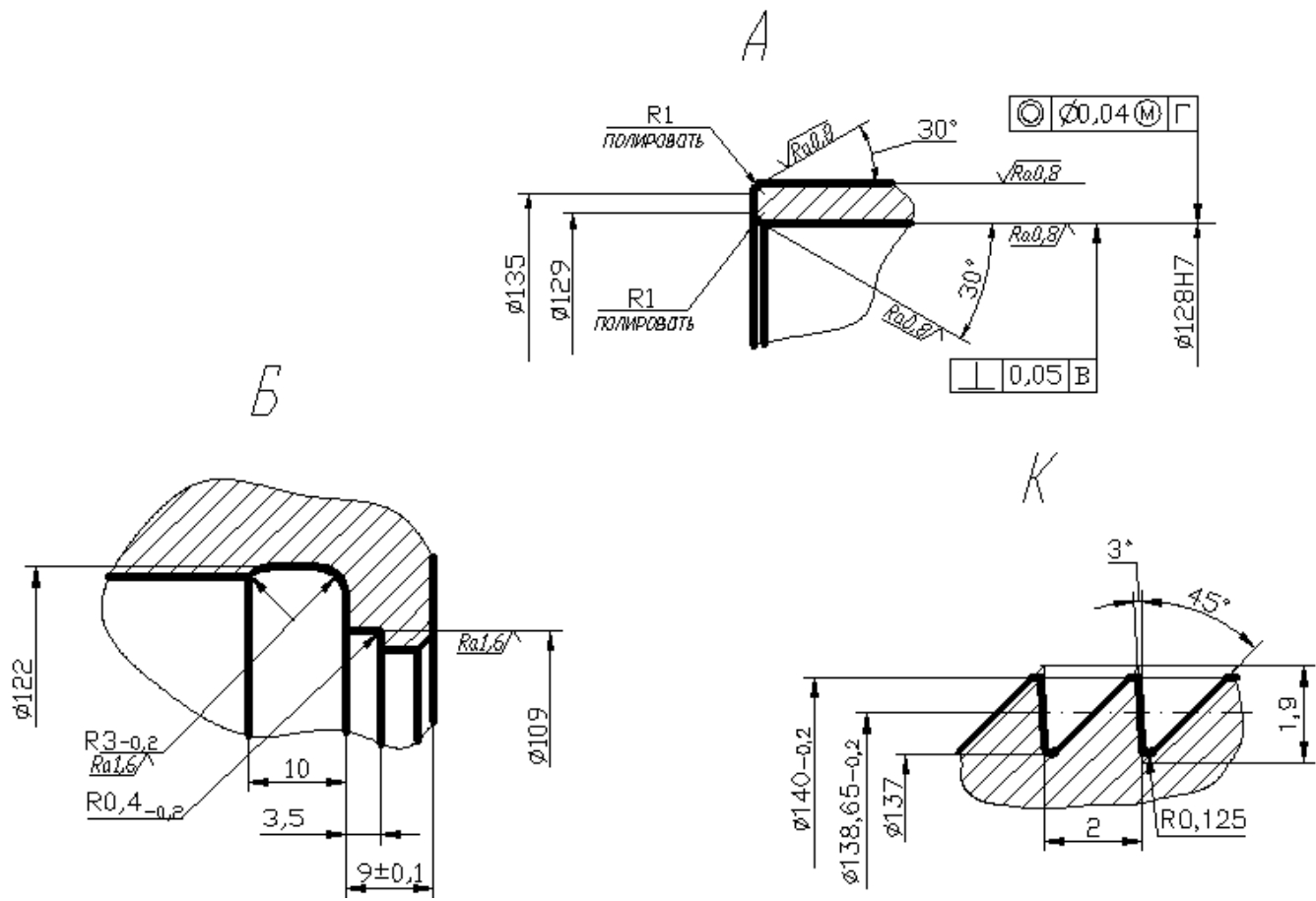

KE





Copied														
Inter.														
Signed										Chng.	Shts.	No. doc.	Signature	Date
													31	10
										TMM.131-ONPM-22.06				
P					PI	D or B	L	t	i	S	n	V	T in	T o
01	continuation of operation 025													
02	5. Boring $\varnothing 129 \pm 0.5$ ; $< 30^\circ \pm 1^\circ$ ; R $1 \pm 0.3$ ; $\varnothing 128H7^{(+0.04)}$ ; R $1_{-0.1}$ , excerpt . p-p 32 $_{-0.1}$ ; $\varnothing 122.5^{+1}$ ; $< 30^\circ \pm 1^\circ$ .													
03	Cutter WNMG-HA 080404-HA PC8110; VD85119-419 calipers; VD86170-1331 hole-gauge; VD8127-4814 standard; VD 86155-3113 caliber indic.;													
04	VD8189-4210 standard; VD8071-0954 tip; inclinometer 0-320° 2'; radius meter 0.1 ÷ 1.2													
05						128	32	3.0	1	0.12	150	60		
06						128	32	0.5	1	0.07	200	78		
07						128	32	0.25	1	0.06	220	92.2		
08														
09	6. Blunt the sharp edges outward. Surface 0.1 ... 0.4 , internal 0.2 ... 0.6. Polish the top. R 1 and R 0.1...0.5													
10	Sandpaper													
11	Non-perpendicularity $\varnothing 128H7$ with respect to the edge no more 0,05 mm, provided by processing in one installation.													
12	Misalignment $\varnothing 128H7$ in relation to the surface G ( $\varnothing 119.7^{+0.1}$ ) slightly more than 0.04 is provided in one installation													
13														
14														
15	B. Reinstall the blank.													
16														
17														
OC														

Copied															
Inter.															
Signed															
										Chng.	Shts.	No. doc.	Signature	Date	
													31	11	
										TMM.131-ONPM-22.06					
P						PI	D or B	L	t	i	S	n	V	T in	T o
01	continuation of operation 025														
02	1. Sharpen the outer contour of the blank														
03	Right cutter, left cutter; 0-250/0.05; VD84311-1084 standard; VD 86150-1348 thickness gauge;														
04	150±0.5; 220±0.5; R100 (2p) – Provide by program														
05	Ensure that the misalignment of the surface $\varnothing 146_{-0.025}$ with respect to the surface $\varnothing 119.7$ and average diameter of the Sp 140x2 thread is no more than 0.01.														
06	Perform threading and grooving $\varnothing 146$ with one installation														
07							-	-	2.5	1	0.21	120	60		
08							-	-	0.5	1	0.12	200	82		
09															
10	2. Sharpen $<30^\circ$ ; R 1±0.3 , excerpt. $\varnothing 135\pm 0.5$ ; $\varnothing 136.2_{-0.05}$ per $l -14\pm 0.2$ , excerpt. R 1±0.3 and $<45^\circ$ ; $\varnothing 140_{-0.2}$ .														
11	Cutter; WNMG - HA 080404- HA PC8110 bracket 140 <sub>-0.2</sub> ; VD81509-8571 caliber; VD85119-412 calipers; radius meter 0.1 ÷1.2.														
12							-	63	-	1	0.1	180	80		
13															
14	3. Sharpen the groove R 3 $<45^\circ$ , excerpt. $6^{+0.12}$ ; $48^{+0.25}$ ;136.5														
15	Korloy cutter for grooves DWLNR 2525- M 08 WNMG - HA 080404- HA PC 8110; 0-250/0.05; 0-250/0.05														
16	R3 ; $<45^\circ$ - provide by cutting tools.														
17															
OC															



Copied																
Inter.																
Signed								Chn.	Shts.	No. doc.	Signature	Date				
													31	13		
Developed	Saranov N.I.				<b>NTU "DP"</b>	<b>TMM.131-ONPM-22.06</b>										
Checked	Derbaba V.A.															
Accepted	Protsiv V.V.															
T. contr.	Protsiv V.V.															
N. contr	Protsiv V.V.						<b>Cylinder</b>							030		

$\sqrt{Ra3,2}$

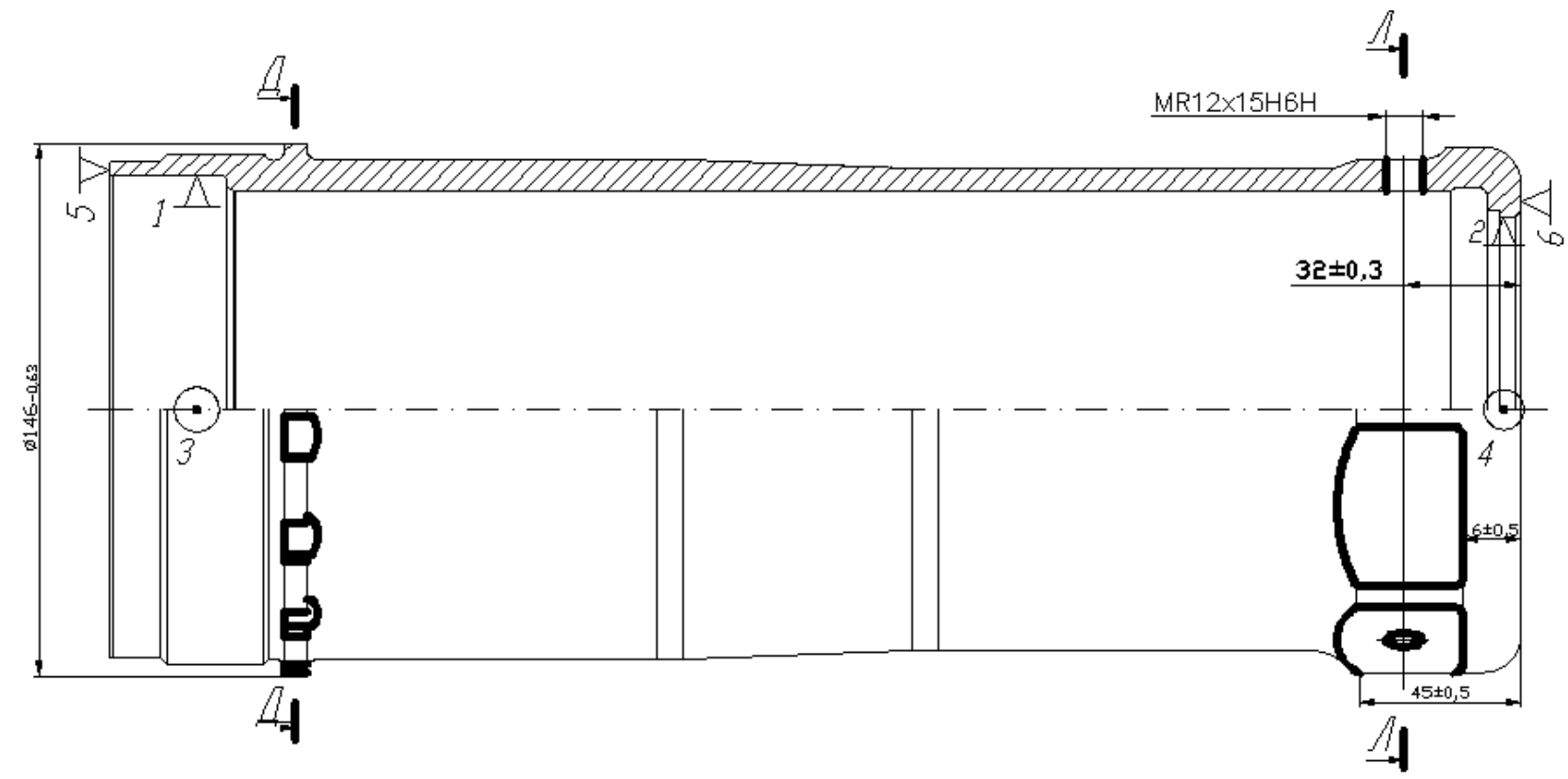

KE

Copied															
Inter.															
Signed								Chn.	Shts.	No. doc.	Signature	Date			
												31	14		
Developed	Saranov N.I.				<b>NTU "DP"</b>	<b>TMM.131-ONPM-22.06</b>									
Checked	Derbaba V.A.														
Accepted	Protsiv V.V.														
T. contr.	Protsiv V.V.														
N. counter.	Protsiv V.V.						<b>Cylinder</b>						030		

√Ra3,2

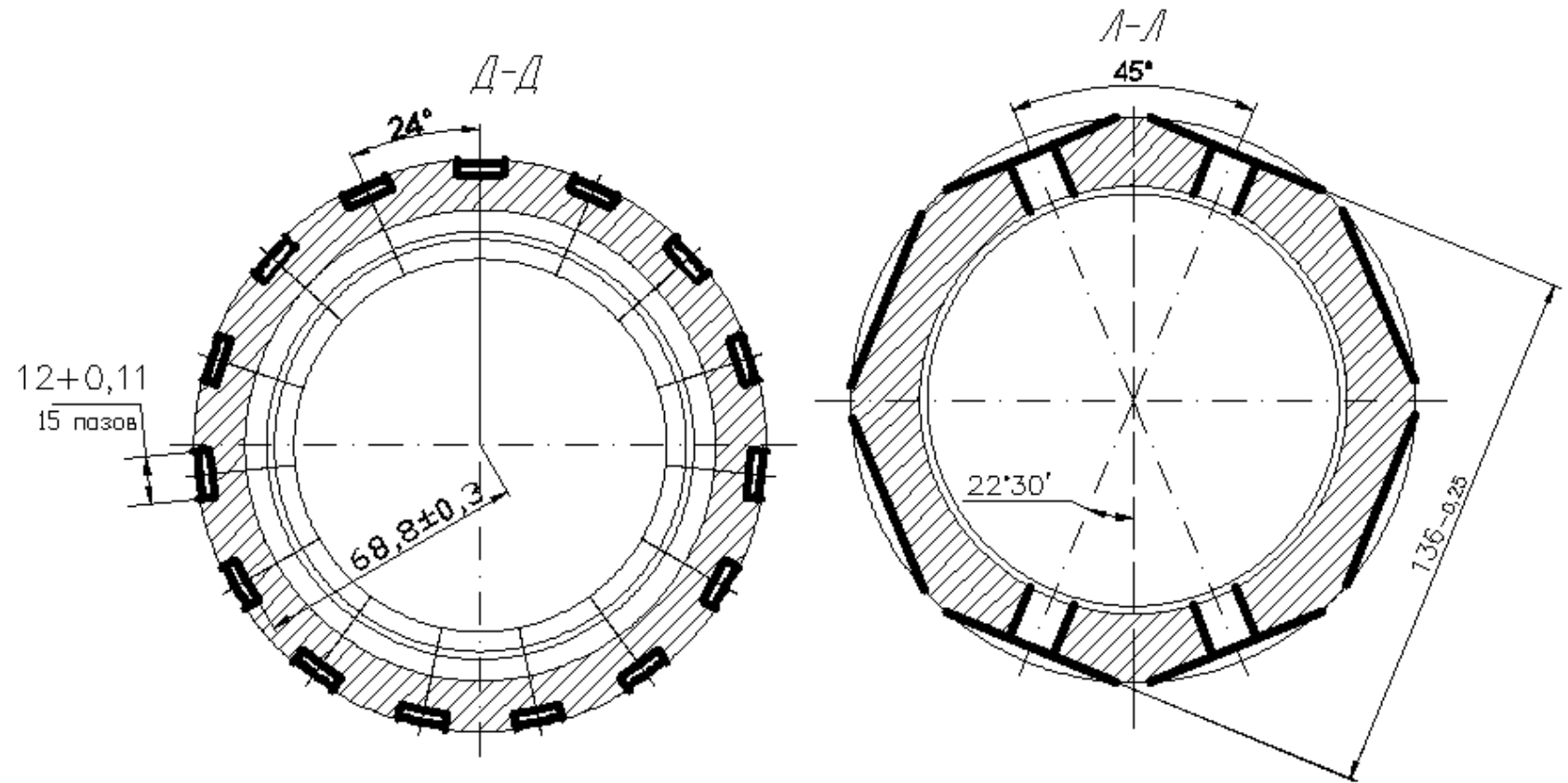



Copied															
Inter.															
Signed															
										Chng.	Shts.	No. doc.	Signature	Date	
													31	16	
										TMM.131-ONPM-22.06					
R						PI	D or B	L	t	i	S	n	V	T in	T o
01	continuation of operation 030														
02	3. Drill 4 holes for thread $\varnothing 10$ , excerpt. $22^\circ 30'$ ; $45^\circ \pm 40'$ .														
03	Korloy MSDPH 0100-5S drill $\varnothing 10$ .														
04							10	14	5.0	1	0.06	530	17		
05															
06	4. Countersink for thread $\varnothing 11.11^{+0.15}$														
07	VD23201-8347 R9M4K8 Countersink $\varnothing 11.18$ ; smooth plug for cutting $\varnothing 11.11^{+0.15}$														
08							11,11	14	0.5	1	0.12	220	8.4		
09															
10	5. Drill chamfers $0.6 \pm 0.1 \times 45^\circ \pm 1^\circ$ for threading														
11	Countersinking 2353-0111 P6M5; boring cutter.														
12															
thirte en															
14															
15															
16															
17															
OC															



Copied														
Inter.														
Signed									Chng.	Shts.	No. doc.	Signature	Date	
										31	18			
Developed	Saranov N.I.			<b>NTU "DP"</b>	<b>TMM.131-ONPM-22.06</b>									
Checked	Derbaba V.A.													
Accepted	Protsiv V.V.													
T. contr.	Protsiv V.V.			<b>Cylinder</b>										
N. contr.	Protsiv V.V.													
Name of the operation			Material		Hardness	EV	MD	Sizes and dimensions			MOZ	COID		
Washing			Alloy VT22 OST 1 90266-86		$\sigma_{1078} \dots 1274$	kg	7.0	Ø146x530			26,19	040		
Equipment, CNC device			Designation of the program		Then	TV	T p.z.	T pc.		coolant				
Bath			-											
R					PI	D or B	L	t	i	S	n	V	T in	T o
01	1. Wash the parts according to the instructions.													
02														
03														
04														
05														
06														
07														
08														
09														
10														
11														
12														
OC														



Copied														
Inter.														
Signed										Chng.	Shts.	No. doc.	Signature	Date
												31	19	
Developed	Saranov N.I.			<b>NTU "DP"</b>	<b>TMM.131-ONPM-22.06</b>									
Checked	Derbaba V.A.													
Accepted	Protsiv V.V.													
T. contr.	Protsiv V.V.													
N. contr.	Protsiv V.V.			<b>Cylinder</b>										
Name of the operation				Material		Hardness		EV	MD	Sizes and dimensions			MOZ	COID
LUM control				Alloy VT22 OST 1 90266-86		$\sigma_B = 1078...1274$		kg	7.0	Ø146x530			26,19	050
Equipment, CNC device				Designation of the program		Then		TV	T p.z.	T pc.		coolant		
Bath				-										
P				PI	D or B	L	t	i	S	n	V	T in	T o	
01	1. Do a luminous control													
	Luminescent flaw detector													
02														
03														
04														
05														
06														
07														
08														
09														
10														
11														
OC														

## Appendix A. Route map of the "Cylinder" in the workshop

GOST 3.1118-82 Form 1																
Double																
Acting																
Signed																
								Chng.	Shts.	No. doc.	Signature	Date				
										Sheets 2	Sheet 1					
Developed	Saranov M.I.			<b>NTU "DP"</b>			TMM.131-ONPM- 22.06									
Checked	Derbaba V.A.															
Accepted	Protsiv V.V.															
T. contr.	Protsiv V.V.			<b>Cylinder</b>												
N. contr	Protsiv V.V.															
M01	Alloy VT22 OST1 90266-86															
M02	Code		Ev	MD	EN	N. r ozh .	KIM	Code of materials		Sizes and dimensions		KD	MOZ			
			kg	7.0	1	1.24	0.267	stamping		Ø153x540		1	26,19			
A	Sh.	Sec.	RM	Oper.	Code, operation name					Designation of the document						
B	Code, equipment name					SM	Prof.	R	UT	KR	COID	EN	VP	D. pc	T p.z.	T pc.
A01				005	Billet							1		60		
B02					GKM											
A03				010	Control							1		60		
B04					Styloscope											
A05				015	Heat treatment									60		
B06					According to the tech. of a thermal workshop											
A07				020	Turning with CNC							1		60	7.0	34.49
B08					Multifunctional center MultiCut 500i (S)											
A09				025	Turning with CNC							1		60	18.0	370.14
B10					Multifunctional center MultiCut 500i (S)											
A11				030	Milling and drilling							1		60	19.0	21.09
B12					Multifunctional center MultiCut 500i (S)											
A13				035	Locksmith							1		60		
B14					Bench											
A15				040	Washing							1		60		
B16					Bath											
RM	ROUTE MAP															



Appendix B. Cylinder blank drawing

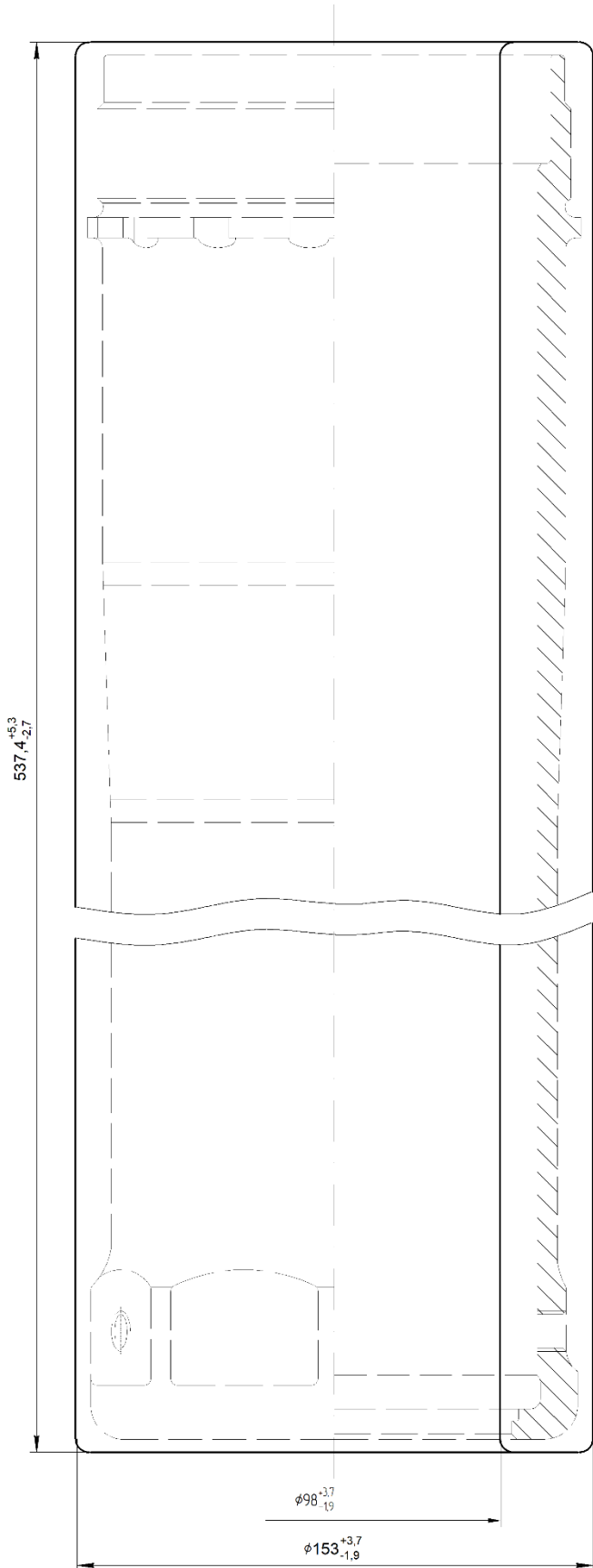

1. Stamping correspond TD 1-92-34-75. Control group II.
2.  $\sigma_b = 1078.1274$  Mpa. Control group 2a correspond OST 1 00021-78.
3. Stamping angle 2°.
4. Unwritten stamping radius 4 mm.
5. Limits for deviation in stamping sizes- correspond OST 141187-78, accuracy class 5.
6. Mark and brand with manufacturer technology.

					TMM.131-ONPM-22.06.01			
Appr.	Revision	Name	Sign	Date	Cylinder (stamping)	Est	Place	Scale
Drawn		Sarantov M. I.					26,19	1:1
Checked						Page 1 / Pages 1		
T. contr.								
M. contr.						Alloy VT22 OST 1 90266-86		
Appr'd								

# Appendix B. Cylinder part drawing

√ Ra3.2 | 1 | √

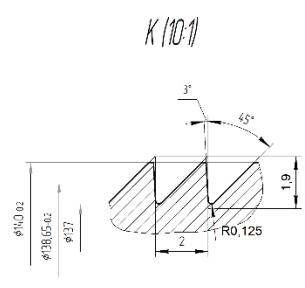
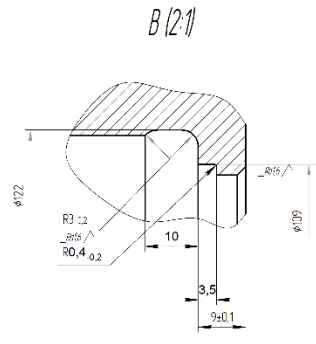
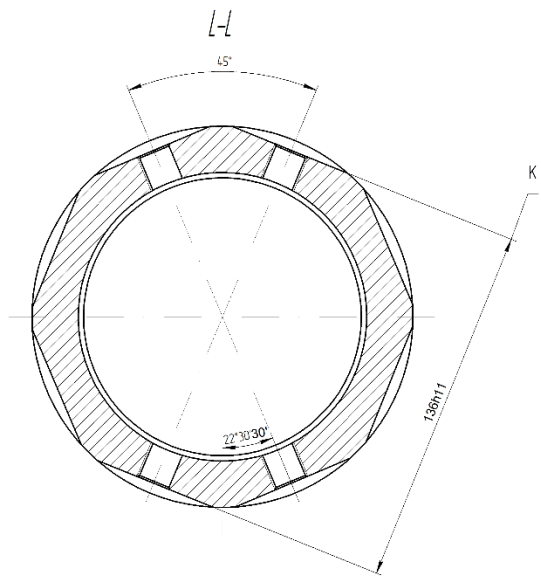
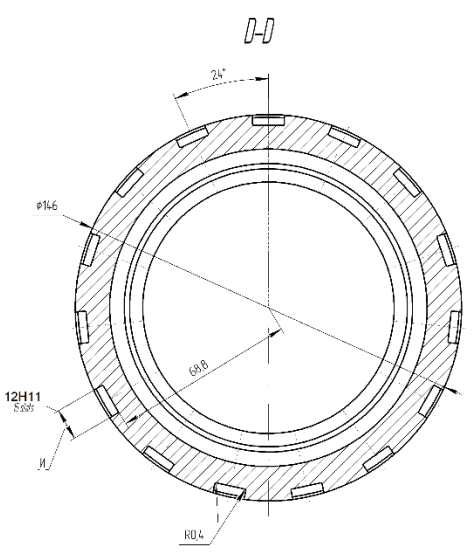
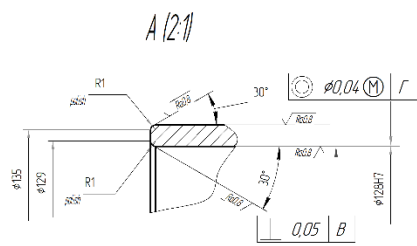
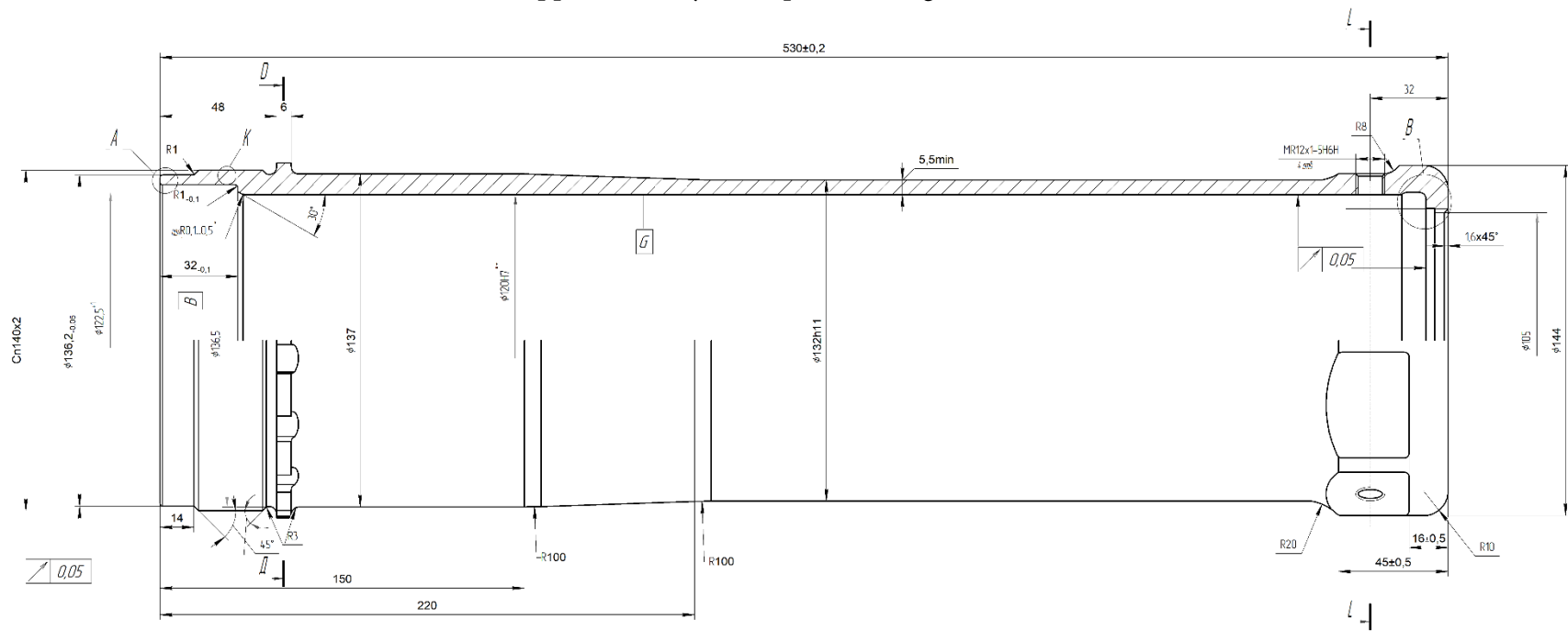

1. Drawing corresponds to model 14.8004.110303000-01
2. σ = B-0378. 1274. M16. Control group 2a according OST1 00021-78
3. Manufactured and controlled according T16-578-02
4. Alpha layer isn't allowed
5. Unspecified edge size, form and position errors of surfaces according to OST1 00022-80
6. \* Round any crooked that don't goes behind specified radius
7. Thread corresponds OST1 00485-83
8. Position for slots and grooves relatively one each other arbitrary
9. Luminescent control LUM-08 corresponds OST1 90282-79
10. Surface coating G - H hardness: 21.4.2
11. \*\* Sizes and roughness after coating
12. Add inscription to the frame with method of low temperature decal, black colour. Font type determined by a technology. Height of the letters and numbers - 6mm.
13. Mark and brand part on the tag corresponds OPI 63-06
14. Other technical requirements corresponds 14.8.004.0503.000.000 TU

					TMM131-0NPM-2206.01			
					Cylinder			
№	Version	№	Sign	Step	№	№	№	Scale
01								1:1
					Page 1		Page 1	

Operation 05 Turning  
 CNC Machine: Kovosvit MAS MultiLat 500 (S)  
 Equipment: 3x jaw chuck DM 55026, fixed lathe

# Appendix B. Cylinder manufacturing operations drawing

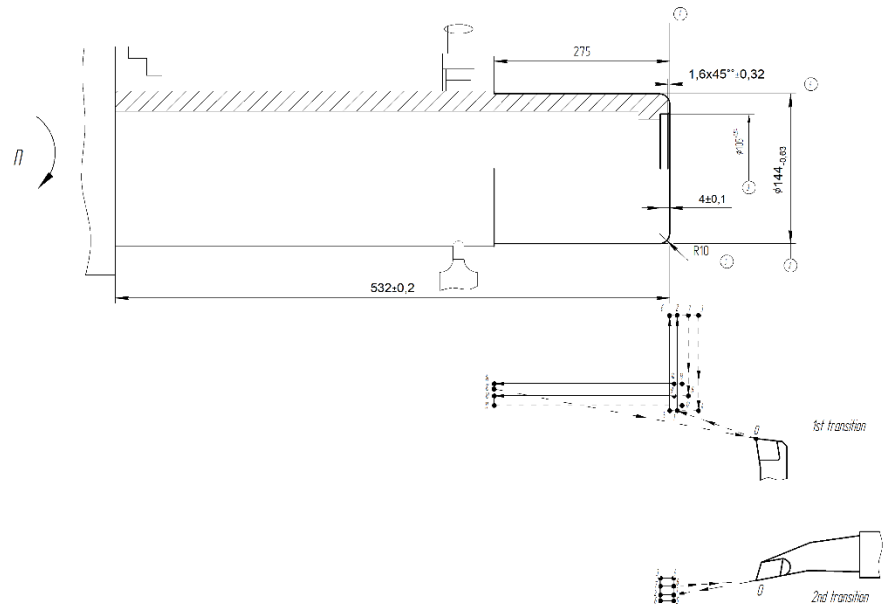

√Ra32

Operation 005 Milling-drilling  
 CNC machine: MultiFunctional center Kovosvit MAS MultiLat 500 (S)  
 Equipment: Collet chuck GABANT 30 5300\_25 HSK-A 63 DM 68893-1

√Ra32

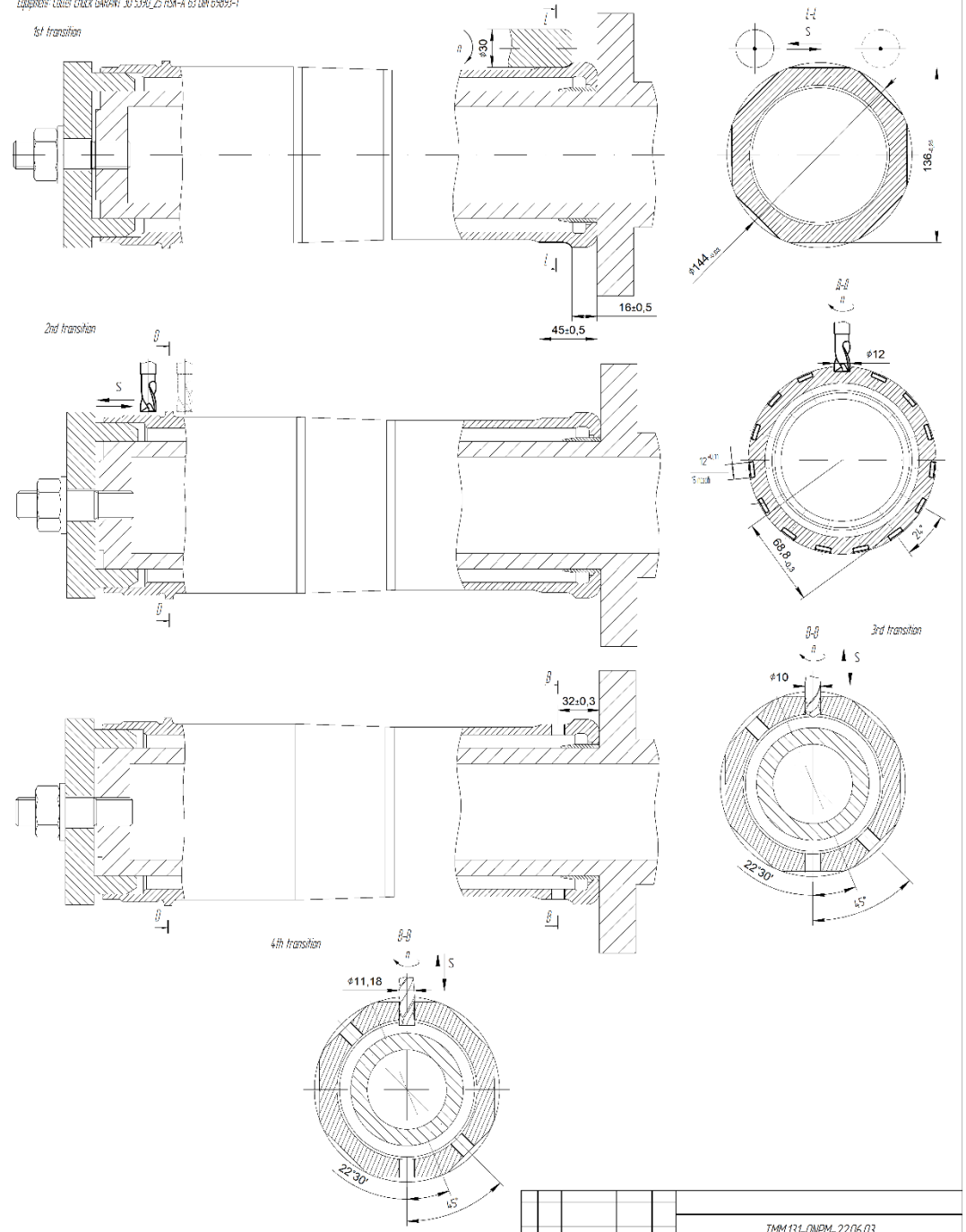

2	Cutting tool: DM 4204-320-150-1-51006-04 55026-M1 R200	0.5	0.10	92.7	280	7.34	2100	T <sub>cut</sub>	T <sub>acc</sub>
		25	0.38	71.3	220				
		0.7	0.1	87	260				
		3.0	0.21	59.96	320				
		10	0.11	66.7	380				
1	Cutting tool: GILAP A20 030M01 15 DM4 55026-R3303	3.6	0.24	76.4	360	7.34	2100	T <sub>cut</sub>	T <sub>acc</sub>
		l	S <sub>c</sub>	V <sub>c</sub>	f				
N. seq.	Cutting tools	mm	mm/rev	m/min	rev/min			mm	mm

N. trans.	Cutting tools	3	Gilap G20M 100M 030 25 15	φ 4.0	0.06	17	530				
		2	P81 Kating 085 420 380 420 12	φ 4.2	0.24	24	650	7.34	2100		
		1	P81 Kating 085 420 380 420 12	φ 4.0	0.8	22	140				
		l	S <sub>c</sub>	V <sub>c</sub>	f	T <sub>cut</sub>	T <sub>acc</sub>				
		mm	mm/rev	m/min	rev/min	mm	mm				

TMM131-0NPM-22.06.03					
Op	Trans	Seq	Op	Seq	
Operations of cylinder processing					
Page 1 Page 2					