

Sergey Matyashuk
 M.V.Gubinskiy, research supervisor
 I.P.Nikitina, language adviser
 National Metallurgical Academy of Ukraine, Dnipro

Thermochemical Regeneration

Of all known methods for process gases production, synthesis gas (mixtures of hydrogen and carbon monoxide different quantitative composition) in particular, the most economically feasible methods are different kinds of oxidative conversion of natural gas (methane). Vapor, carbon dioxide, oxygen and mixtures of the foregoing various components are mostly used as hydrocarbon oxidant.

Physical and chemical bases of conversion of hydrocarbons are in their oxidation with oxygen, water vapor and carbon dioxide:

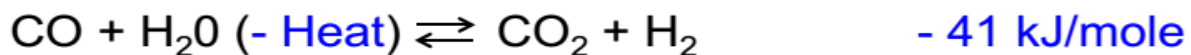
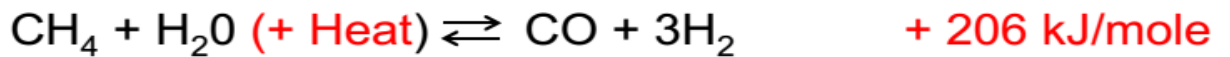

Choosing the type of oxidizing agent and the number of members is determined by the intended purpose of the process and feasibility study.

Idea of TCR heat of flue gases is in the use of sensible heat for endothermic pre-processing of hydrocarbon fuel, which thus receives a larger supply energy chemically bound in the form of increased heat of combustion. If traditional HTI fuel energy is converted to heat in a single step by means of its direct combustion, in installations with TCR fuel energy conversion process is divided into two stages.

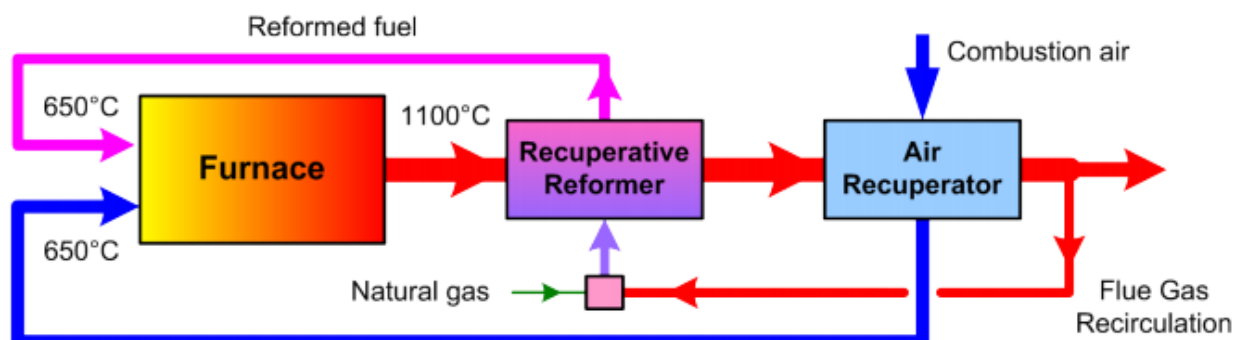

Fig. 1.

The first step - the heating of the reaction mixture and carrying out endothermic reactions, thermal conversion of the propellant, thereby increasing its

calorific value. The second step is the combustion of reaction products, i.e., reformed gas which has higher calorific value compared to the original fuel.

The active catalysts of methane steam reforming are the metals of the 8th group. A number of their activities is: Rh, Ru > Ni > Ir > Pd, Pt > Co, Fe.

The most active catalyst is Rh, (catalytic activity which is 13 times higher than Ni). The iron and cobalt in a vapor conversion are oxidized and deactivated, but noble metals are expensive. That is why the only industrial catalyst for steam reforming of methane is nickel deposited on the various carriers. Oxide ceramics: MgO, MgAl₂O₄, ZrO₂A is a typical carrier for the nickel catalyst is a steam reforming.

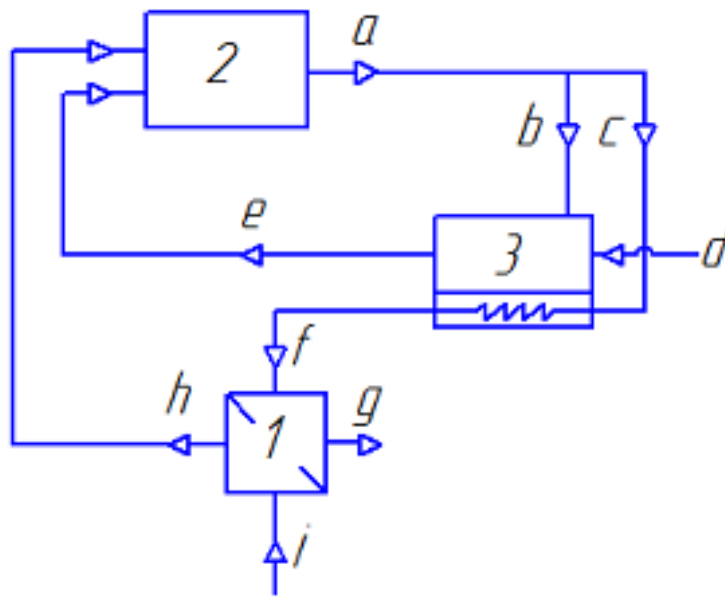

Fig. 2. Schematic diagram of the HTI thermo-chemical heat regeneration of flue gases.

1 - air heater; 2 - HTI; 3 - thermo-chemical reactor; a, b, c - the exhaust fumes; d - natural gas; e - converted gas; f - the partially cooled flue gases; g - the outgoing flue gases; i and h - cold and hot air, respectively.

References:

1. Access mode: <http://naukarus.com/proizvodstvo-i-ispolzovanie-sintez-gaza-v-sistemah-termohimicheskoy-regeneratsii-teploty-dymovyh-gazov>
2. D.I.Pashchenko, dissertation investigation "Improving the energy efficiency of high thermal technological component by thermochemical heat recovery."
3. V.C. Arutyunov, O.V.Krylov. The oxidative conversion of methane,-Russian Academy of Sciences, Institute of Chemical Physics named after N.N. Sewmenov-Moscow, "Nauka" 1998.