

ЕЛЕКТРОПОСТАЧАННЯ ТА ЕЛЕКТРОУСТАТКУВАННЯ

UDC 622.625.28

O. Sinchuk, ScD., E. Guzov, PhD., I. Sinchuk, PhD.

(Ukraine, Krivyyi Rih, SIHE 'Kryvyi Rih National University')

S. Yakimets, PhD, V. Chernaja

(Ukraine, Kremenchuk, Kremenchuk Mykhailo Ostrohradskiy National University)

METHODS SANS SENSORS CONTROL OF SOME PARAMETERS AND SOME OTHER ELECTRIC ELECTRIFIED SPECIES MINE TRANSPORT

More than a third in the overall cost of ore underground mining up energy costs [1]. However, unlike other methods of mining, electricity costs are about 90%. Slow process security and reduce turnaround time operation of electrical equipment rail locomotive structure mining equipment, which mainly the delivery of minerals to the place of lifting to the surface due to the lack of structural parameters of traction control devices in their control systems. In operation currently in the mine and mines Ukraine is about four thousand electric twenty kinds of obsolete equipment that needs upgrading current with the latest developments. In addition, the domestic mining and metallurgical complex of underground technology of work include among the most dangerous because of the possibility of electric shock and statistics of occupational injuries (because of this factor), which in recent years have grown steadily [2]. Reduction factor inefficient operation of electrical transport, increase its operational safety and reliability possible when constructing and application of modern control systems and electrical current technological parameters of electric train (ET) as it moves using sans sensors monitoring systems.

Control temperature conditions. Improving the reliability of a power electric motors (PEM) is impossible without current control temperature regimes of all types of electric motors in electrical traction complexes (ETC) mine electric [4,5]. The experience of the operation of electric transmission, use only of continuous temperatures the thermal control regimes of PEM reduces the failure last 30...35% of failure collectors 2.6...3.3 times, circular lights in them 3.1...3.7 times for a total reduction collectors 2.8...3.4 times [6]. Operating without PEM systems for heat mode increases the number of failures in 1,5...3,5 times.

By measuring the temperature of electrical machines put forward the following technical requirements [7]: measurements made in the right spots at different heating modes; making minimum range of thermal irregularities in the process of measurement; the ability to perform remote measurements, mainly direct method of direct assessment of electromagnetic fields and environmental conditions; independent measurement results of vibration; high accuracy of measurement; applying for temperature measurement simple and standard equipment.

Really possible means of temperature control traction engines and build appropriate protections are: laying the engine temperature sensors; use of thermal relay; indirect assessment based on measuring motor windings resistance calculations or losses in the engine.

The most accurate and most commonly used method is the direct evaluation of the winding temperature steel or active sensors embedded in the motor temperature. The main drawbacks of this method is the same need for constructive laying in winding engine in operation without disassembly impossible. The need for additional output from the motor wires in a highly PEM vibration can cause them damage and failures of protection.

Thermal relays efficiently applied in the protection of motors with permanent or load, which varies slightly. If excess current regime long thermal relay changes too quickly could cause a "racing machine" and therefore unsuitable for motor protection from overheating.

The calculation of energy loss in traction motors for the billing period allows indirect assessment of its heating. When applying this method during the engine break at intervals during which the motor current can be considered constant. In terms of iron ore mines motion cycle is:

$$T \leq t_{utw} + t_{load} + t_{lrc} + t_{hnd} + t_{man} + t_{dow}, \quad (1)$$

where t_{utw} , t_{load} , t_{lrc} , t_{hnd} , t_{man} , t_{dow} – under a train without a load, loading, loaded traffic composition, handling, maneuvering and downtime.

Given the formula (1) is equivalent current can be represented as:

$$I_{eqv} = \alpha \sqrt{\frac{1}{T} \left(I_{utw}^2 t_{utw} + I_{load}^2 t_{load} + I_{lrc}^2 t_{lrc} + I_{hnd}^2 t_{hnd} + I_{man}^2 t_{man} + I_{dow}^2 t_{dow} \right)}, \quad (2)$$

where α – coefficient for iron ore mines is considered equal to 1.4, and taking into account the deterioration of engine cooling during maneuvers and stops. In modern microprocessor control locomotives can be implemented directly estimate the energy loss, which is proportional functions I^2t , integration of functions and determine the equivalent current according to the expression (3)

$$I_{eqv} = \alpha \sqrt{\frac{1}{T} \int_0^T I^2 dt}, \quad (3)$$

If the calculated value exceeds the rated current long mode I_{nLM} , triggered protection that sends a signal to the driver or affect the disconnection drive.

The magnitude of the resistance of the windings can be determined by the average temperature of the winding. The method is based on the properties of the winding resistance changes as a function of temperature.

The temperature of the hot coil is given by:

$$t_h = \frac{R_h - R_c}{R_c} (k + \tau_c) + \tau_c, \quad (4)$$

where R_h , R_c – support windings are measured, respectively, in the hot and cold; τ_c – famous winding temperature in a cold state in which the measured resistance R_c ; k – the reciprocal of the temperature coefficient of resistance for 0°C and that takes a value of 235 for the copper windings and 245 – for the winding of aluminum; τ_c – winding temperature in almost cold.

Based on the expression (4) for the copper windings can be written:

$$\Delta t_h^{Cu} = \frac{R_h - R_c}{R_c} (235 + \tau_c) + \tau_c - \tau_{cm}, \quad (5)$$

where Δt_h^{Cu} – excess temperature hot copper winding temperature τ_{cm} cooling medium.

In the real level of accuracy measurement of resistance of 1% and a temperature of 130°C hot winding temperature measurement error C temperature method is 2.8% or 325°C , which is quite acceptable.

According to research, the most dangerous heating occurs in the armature winding. Control of resistance and corresponding temperature accompanied by great difficulties associated with the brush contacts. Their resistance is connected in series with the armature winding, unstable and can vary tenfold depending on the brand of brush, they attach to the work surface condition and its collector temperature, speed. Moreover brush cover several collector plates with shunt winding section anchor. So enough temperatures accurately anchor for its winding resistance impossible. However, there is another way - to control the temperature resistance of the winding. This can be based on the following considerations: winding traction engines include series with the armature winding because it runs the same current; windings located in one machine, so they are heating and cooling interrelated. This allows for the winding temperature accurately determine the temperature anchor.

Research temperature distribution, the authors conducted on a laboratory bench showed that at the maximum allowable temperature armature winding it heats 25°C higher than winding.

Given that the allowable temperature for armature winding insulation class F is 155°C , the maximum allowable temperature for heating armature winding is $155-25=130^\circ\text{C}$.

Thus, despite the fact that the winding and allows a higher temperature, protection against overheating engine should operate at a temperature of winding 130°C , which corresponds resistance:

$$R_h = R_c \frac{235 + \tau_h}{235 + \tau_c}; \quad (6)$$

or, if $\tau_h = 130^\circ\text{C}$ and copper windings:

$$R_{130}^{Cu} = R_c \frac{365}{235 + \tau_c}, \text{ Om.} \quad (7)$$

Fig. 1 shows a possible embodiment of a circuit protection traction electric motor from overheating. The average value of the voltage U is removed from the winding health WH through the circle, which consists of R1–R2 and that C limits voltage pulses at commutations in the power unit circle, which is protected. The average value of current I that flows through WH, determined by the shunt. Set up protection for a specified resistance exercise and proper temperature resistor adjustment R3

Block protection device includes an integrated analog divider, which acts as a division U_{av}/I_{av} – that continuously measures the resistance value windings. Upon reaching the resistance value, which corresponds to a temperature of 130° C winding, protection work, armature winding temperature with temperature reaches 155° C. The scheme does not require the engine temperature sensors – directly winding engine is a sensor. This makes protection simple and reliable. In this structure as a real option divider for practical implementation can serve as a chip-I 4-Quadrant Multiplier/Divider AD734 © Analog Devices, Inc. The scheme supports two modes of analog division.

The chip recommended as an analog divider, which operates on a direct voltage regulation denominator. This mode is more accurate, flexible and can increase the frequency of the chip, because all inputs are available. Typical greatly divider provides performance functions:

$$W = \frac{(X_1 - X_2)(Y_1 - Y_2)}{(U_1 - U_2)} + Z_2,$$

where X, Y, Z – signals that can be both positive and negative, but the difference signals must be positive and be within 10 mV ... 10 V

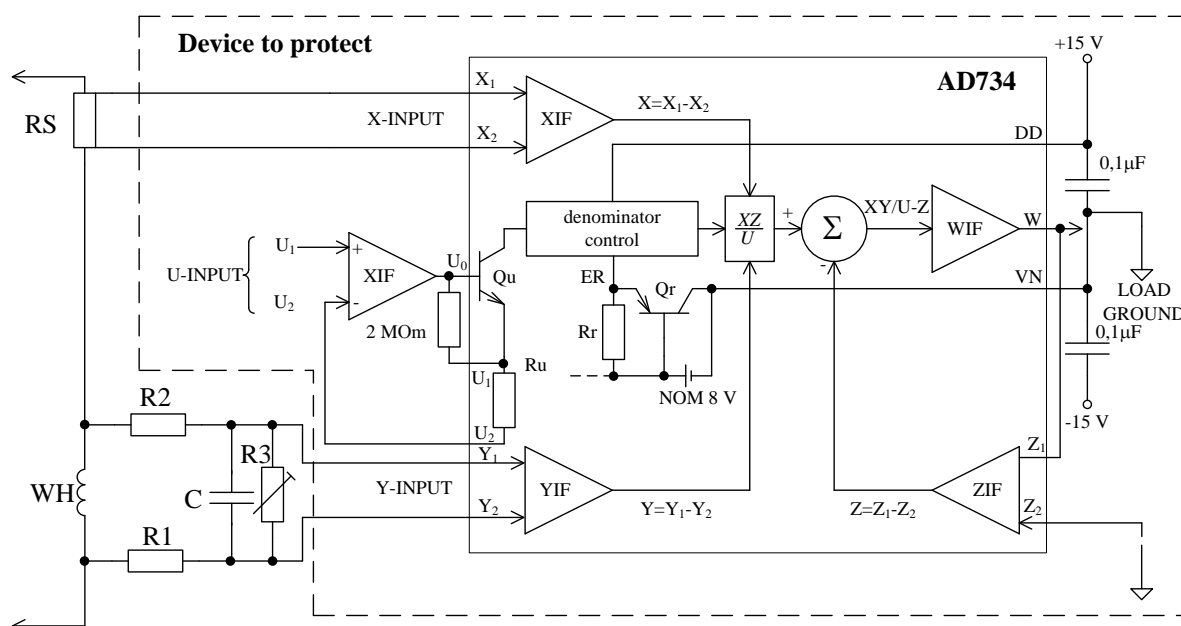

Fig. 1. Protection Scheme mine electric traction motor from overheating using AD734

Monitor the status of batteries. During the operation traction batteries total control voltage on the battery. During charge and discharge it varies over a wide range, and the failure of some of its elements remain unnoticed. It is therefore assumed periodic re-verification of the status of individual batteries in the battery disconnected using a portable load forks with a voltmeter.

The disadvantage of this method is that permanent functional testing elements of the battery is not in operation [5]. As a result of reduced reliability of batteries and increase the cost of their operation, especially in mines and mines. Specialized microprocessor control system failure detection and processing [8] allow continuous monitoring of voltage in the battery cell. However, the disadvantage of the said technical solution is its complexity: microprocessor control with lots of connecting conductors to connect to each battery element 20 is costly in maintenance and reliability while reducing their operation. The proposed technical solution allows authors to simplify system control battery status, reduce costs and increase reliability. Faults in the battery voltage is determined by comparing the two halves of the battery. The control made as a voltage divider and device for con-

trolling voltage difference between the two parts of the battery pack. Volt performed using resistors connected in series, are connected to the battery contacts. The device controls the difference between the average voltage connected point the battery and the average point divider voltage. Battery to the control device connected to the load or charger. In the presented Fig. 2 [9] control device is implemented as a digital voltmeter constantly in current chip PIC16F676 14-Pin FLASH-Based 8-Bit CMOS Microcontrollers © Microchip Technology, Inc. Device control voltage difference on the two halves of the battery is between point "a" and the middle point voltage divider "b". Volt performed consistently combine them, resistors Rd1 and Rd2 that connect to the battery contacts ("+", "-"). With the inviolability of the battery in all operating modes - both when charging and loading mode - point "a" and "b" practically equipotential and tension between them is close to zero. In case of malfunction battery - such as short circuits or breaks within individual cells or short circuit or external connections cliffs battery cells, changes in the internal resistance and the resistance element between compounds of capacity, change pole elements, etc., – the balance is disturbed and 'is the voltage that will be recorded device control.

Control the speed of the mine locomotives. One of the parameters that must be controlled and, moreover, if necessary, play is the speed of the train. More of this option is strictly regulated by the Rules of Safety in Coal Mines [3] differentiated on-site underground electric technological route. This fundamental condition for security is the speed limit when driving the locomotive by allowable braking distance that the carriage of goods shall not exceed 40 m, and the transport of personnel - 20 m [3]. Stopping distance train in conditions calculated worst case - the movement of cargo the slope to the shaft. This site is the most dangerous, speed limit it to 10 km / h, although (for towing capacity) train can reach a much higher speed. At various time periods types of mine locomotives developed and in use by now the whole "line" devices Speed trains including mine [5]. So in [10] shows the variations of speed meters installed on mine electric locomotives type 10KR, 14KR production Alexandrovka engineering plant (Russia).

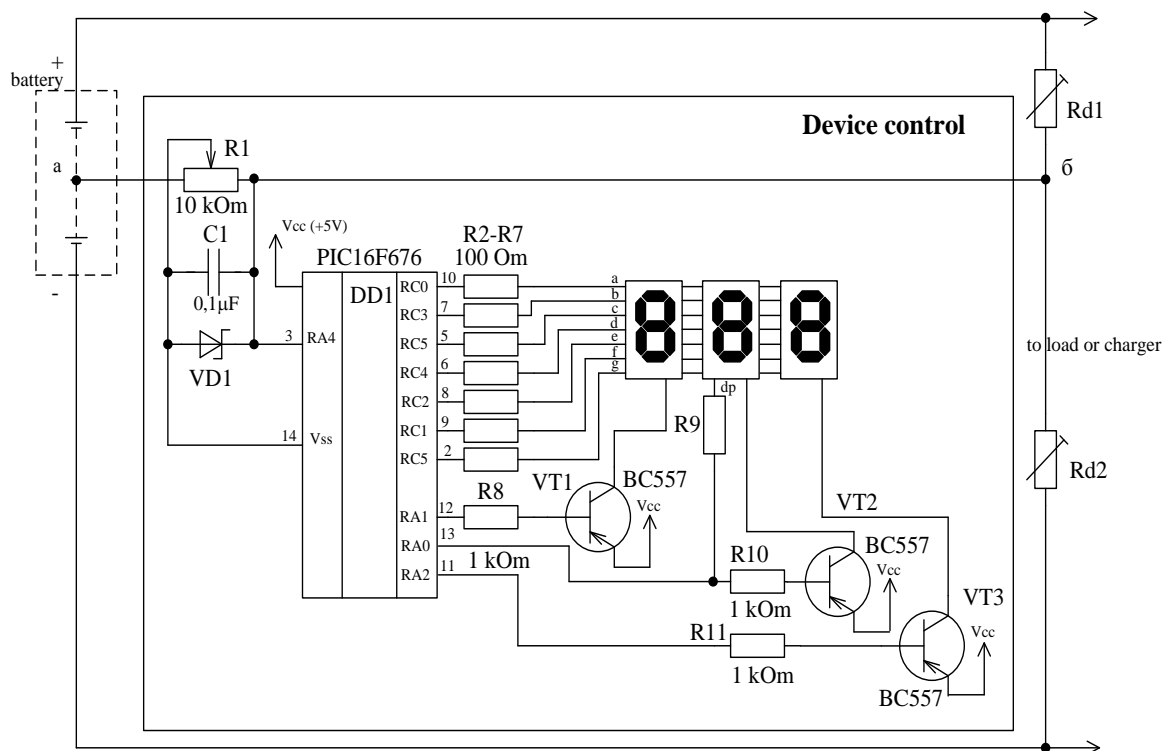

Fig.2. Scheme condition monitoring battery

The system includes a first sensor unit generator permanent magnet that generates a current whose magnitude is proportional to the rotor speed. The system includes a first sensor unit generator permanent magnet that generates a current whose magnitude is proportional to the rotor speed. The second unit - magnetic tachometer that plays these currents and shows velocity on electric remote control driver. Sensors installed on the cover of the gear transmission electric traction and connect the gear reducer, with the help of my own gear. As you can see, even a priori obvious difficulty of such a device. According to [2], a type of mine electric locomotives manufactured by LG ASEA (Sweden) to control the speed of the electric locomotives have two options. In the first set of sensors for all-lu traction gear transmission, the second - built in constructively traction engines. Both

methods have the same set of disadvantages as those that have been considered before. To control the speed of the national transport currently use a number of methods, which are based, in fact, responsible for monitoring rotational speed of electric motors or traction bogies, followed by a re-train speed in [5].

However, if conditions locomotives that operate in ground conditions as the first and second versions of these control systems in one way or another is acceptable, then the conditions of use of the underground to achieve the required efficiency problematic. Reliability meter speed can be increased repeatedly, using the method of speed sans sensors using only the electrical parameters of the mode of electrical traction-algebraic engines. It is known [11] that PEM sequential excitation voltage and current values uniquely determine the speed of rotation. In general, the rotational speed of the traction electric motor is:

$$\omega = \frac{U_a - IR_a}{C_\omega F}, \quad (8)$$

where U_a – armature voltage; I – current and armature winding; R_a – armature winding resistance; F – magnetic flux; C_ω – constructive factor.

In electric traction is commonly used linear speed electric:

$$v = \frac{U_a - IR_a}{C_v F}, \quad (9)$$

In (9) changed only coefficient C_v . For PEM series excitation magnetic flux $F = f(I)$, while

$$v = \frac{U_a - IR_a}{C_v f(I)}, \quad (10)$$

We introduce some simplifications are applied to the operating range of regimes. Magnetic flux is a complex dependence on current due to saturation of steel, but with sufficient precision, this dependence can be expressed with exponent $x < 1$ hyperbole, that is $F \approx I^x$. Also negligible value $U_a \gg I_a$. Then the expression (10) is transformed into the equation:

$$v = \frac{U_a}{k I^x}, \quad (11)$$

Using the electromechanical characteristics of the traction motor and asking current I value can determine the appropriate speed and calculate the value of v in kI^x . Calculations show that for different characteristics exponent $x = 0.4 \dots 0.6$. If is set to x , the coefficient is k communication:

$$k = \frac{U_a - IR_a}{v I^x}, \quad (12)$$

To illustrate in Figure 4 shows the electromechanical characteristics of the traction electric motor DTN-45/27 K14 engine.

The rate of movement of electric calculated by the formula (12) in the sense exponent $x = 0.5$. When calculations revealed that the operating range of currents and speed error caused by inaccurate methods does not exceed 5%, which in this case is acceptable. At a current of $I_b > 260$ A pulling force exceeds allowable under the terms of grip and this range represents only theoretical interest. The proposed method of speed sans sensors can be implemented with a measuring unit that is able to perform computational functions and presented in Figure 4. The input of the measuring unit control driver electric voltage serving anchor U_λ and current value of each of the two traction motors. As DC current sensor can be used measuring the extent, were carried shunt or other type of sensor. The measuring unit performs the calculation speed of the electric current according to equation (12) gives the value of speed and the score or device registration. If you exceed the speed above the permissible value signal lamp is lighted. Also on board or device output current value of the engine to inform the driver about the current load.

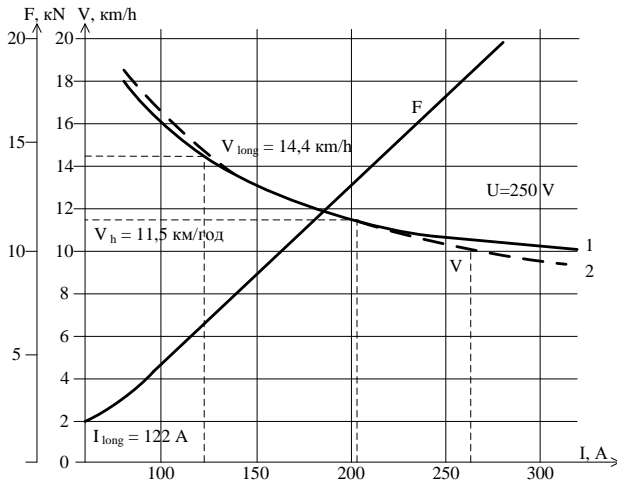

Fig. 3. Electromechanical characteristics of the traction motor DTN-45/27 mine locomotive K14: 1 - actual; 2 - calculated by the proposed method

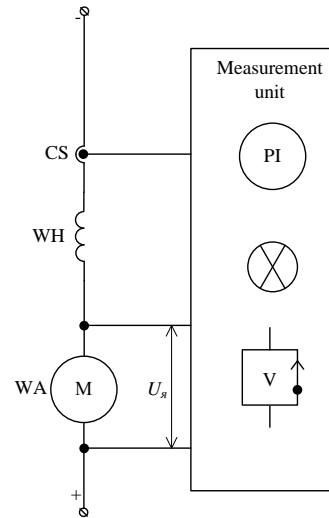

Fig. 4. Block diagram of measuring speed

Conclusions. The analysis and evaluation conducted qualitative indicators of functioning units of temperature modes, condition of batteries and speed meters that app-owl in traction electromechanical systems with traction motors DC series excitation electric modern mine. Established the main reasons for their low reliability and simultaneously identified areas of improvement - no sensor control methods. The results of the research proposed functional and structural schemes meters recommended for implementation.

References

1. Sbornik tekhniko-ekonomicheskikh pokazateley gornodobyvayuoshchikh predpriyatiy Ukrainy v 2009–2010 gg. Analiz mirovoy kon'yunktury rynku GRS 2004–2011 gg. / E.K. Babec, L.A. Shtan'ko, V.A. Salganyk I dr. – Krivoy Rog: Vydavnychiy dim, 2011 – 329 p.
2. Sinchuk I.O., and Skapa E.I., Elektrotravmatyzm i shlyakhy yoho zmenshennya pry ekspluatatsiyi elektryfikovanykh vydiv transportu na pidzemnykh hirnycho-rudnykh pidpryyemstvakh [Electrochromatic and ways of its Reduction in the Operation of Electrified Transport Modes in Underground Mining Enterprises], (2011), Elek-tromekhanichni ta Enerhetychni Systemy, Metody Mode-liuvannia ta Optymizatsii. Zbirnyk Naukovykh Prats IX Mizhnarodnoi Naukovo-Tekhnichnoi Konferentsii Molo-dykh Uchenykh i Spetsialistiv. KrNU Publ., Kremenchuk, Ukraine, pp. 338 – 339. (In Ukrainian).
3. NPAOP 10.0-1.01- 5. Pravila bezpeki u vugl'nykh shahtah [Safety Rules in Coal Mines], (2005), Lugansk, Ukraine, Kopi-centr Pub., 196 p. (In Ukrainian).
4. Chornaya V.O. K voprosu analiza povrezhdenij tjavovykh dvigatelej shahtnyh jelektrovozov [To the Ques-tion of Analy-sis of Damages of Hauling Engines of Mine Electric Locomotives], (2013), Molod: Nauka ta Innovat-siyi. i VseukraYinska Naukovo-Tekhnichna Konferentsiya Studentiv, Asprantiv i Molodih Uchenih. Dnepropetrovsk, Ukraine, SIHE “NSU”, pp. 421 – 422 (In Russian)
5. Volotkovskij S.A. Rudnichnaja jelektrovoznaja tjaga [Miner Electric Locomotives Pull], (1986), Moscow, Russian Fed-eration, Nedra Publ., 389 p. (In Russian).
6. Noskov V.I. Kontrol' i diagnostika motor-vagonnykh poezdov s ispol'zovaniem neyronnykh setey. / V.I. Noskov, M.V. Lipchanskiy, V.S. Blindag // Nauk. tekhn. zh. “Komunal'ne gospodarstvo mist”. – Khar'kov: KhNAMG. – 2011. – Vyp.101. – pp. 278–283
7. Lagutin V.M. Vyprobuvann'a elektrychnykh mashin i transformatoriv v elektroenerhetychnykh systemakh: navch. posib. / V.M. Lagutin, V.Ts. Zelins'kiy, O.B. Burykin. – Vinnytc'a : VNTU, 2010. – 115 p.
8. Khechinashvili A. Mikropocessornye sistemy bezopasnosti khimicheskikh istochnikov toka. VI megd. konf. “Fundame-nal'nie problemy elektrotekhnicheskoy energetiki”. Saratov, izd. Saratovskogo universiteta, 2005, pp.406–408
9. Patent Ukrainy 93384 B03 C1/005. Sposib vyavleniya nepoladok v akumulyatornykh batareyakh / L.V. Smenova, A.A. Petrichenko, E.S. Guzov, O.M. Sinchuk, I.O. Sinchuk; opubl. 27.05.2013
10. Butt Ju.F., Shahtnyj podzemnyj transport: spravochnoe izdanie. Shahtnyj lokomotivnyj i rel'sovyj transport / Ju.F. Butt, V.B. Grjadushhij, V.L. Debelyj, A.N. Koval', A.L. Furman, V.M. Shhuka, V.A. Jacenko [Mine Under-ground Transport: Reference Media. Mine Locomotive and Rail Transport], (2009), Donetsk, Ukraine, VIK Publ., 481 p. (In Russian).
11. Rozenfel'd V.E. Teoriya elektricheskoy tyagi / V.E. Rozenfel'd, I.I. Isaev, N.K. Sidorov, M.S. Ozerov. – M.:Transport, 1995. – 294 p.

Рекомендовано до друку: д-ром техн. наук, проф. Шкрабцем Ф.П.