

A.I. SHEVCHENKO, PhD

(Ukraine, Dnepropetrovsk, Institute of Geotechnical Mechanics by N.S.Poljakova NAN Ukraine)

DIVISION INTENSIFICATION ACCORDING TO FINENESS AND DEHYDRATION OF RAW MATERIALS AT THE NEW WAY OF VIBROSHOCK GRATING

Results of pilot studies of a new method of a vibroshock screening with use for an intensification of a loosening of large particles are given.

Dependences of humidity above deck and the maintenance of classes in products from a ratio of large particles to small and specific loading are received.

The vibration grating is widely applied at division of raw material fineness and dehydration. The most difficult operations are these ones for the damp raw material processing created from wide fineness classes (for example, sludge, construction sand, etc.) when it is necessary to separate thin classes with particle sizes less than 0,1-0,2 mm and to remove moisture as much as possible from a above grate product. Depending on the particle size and humidity the dominating role is played by various forces. At a thin and hyperfine grating they are forces of a superficial tension for which overcoming considerable energy consumption [1-4] is required.

In the traditional ways such raw materials are dehydrated only to 18-22%. Raw material division to a fineness less than 1 mm doesn't give high results, and at the particle size less than 0,2 mm in some cases they aren't classified at all because of their sticking to a sifting surface [1-4].

The review of these process intensification ways has shown availability of impulse influence which can be reported both to a sifting surface, and processed raw materials [1-4]. However successful realization of such influence significantly depends on schemes and dynamic parameters of a trammel. Therefore search of conditions which will provide division efficiency increase and dehydration is necessary, and the task directed on these question solution undoubtedly is actual.

At researches [1-4] for impulse influence on a sifting surface and processed raw materials modes with "double blows" [2-5] were used. At "double blows" during excitement except the basic impulse the additional one is put. At the expense of the basic impulse the above grate product is thrown and during its flight the additional impulse is reported to a sifting surface, which strengthens its fluctuations. Hence there is a rupture of capillary bridges and stability loss of capillary meniscuses in a cell of a sifting surface, division and dehydration process improves. Researches showed possibility of a class - 0,1 mm to 30-35% extraction at humidity decrease of a above grate product to 14-15%. Higher rates weren't reached because part of raw materials balled up.

Application of the disintegrated elements (DE) [3, 4, 6] allowed due to dynamic influence by the intelligence normal and shift impulses to raw materials and to a sifting surface, to overcome superficial tension forces. Due to impulse inflictions sifting

Dehydration and drying. Water sludge economy

surface fluctuations amplify that increases division efficiency and dehydration. This decision succeeded to reduce humidity of a above grate product to 10-12%, and extraction of classes of -0,1 mm into a under grate product increases to 45-50%.

To increase grating efficiency it is necessary to intensity a raw material loosening and to overcome superficial tension forces for removal of capillary and butt water [1-3]. For this purpose The vibroshock grating method [2-7] is offered consisting in the following. The trammel box and the activator excite harmonic oscillations which are transformed by shock elements into impulses. Material is given on the activator installed over a sifting surface at distance, less than height of a material tossing where under the influence of the activator compelled fluctuations the material is loosened for free movement through activator openings on the sifting surface. Due to interaction of shock elements with a sifting surface its fluctuation strengthen, and as a result the above grate material is thrown. While the material separation from a sifting surface and before its falling it is imparted the additional impulses due to activator fluctuations.

In addition the activator is excited disintegrate elements for strengthening of impact on a divided material and liquid in local areas by normal and shift impulses which are changed on activator length. Hence there are a capillary bridges rupture and capillary meniscuses stability loss in a sifting surface cell, material division in particle size and sifting surface cleaning of the particles which have got stuck in cells and the stuck material that improves classification and dehydration process. Application of this way allowed to reduce a above grate product humidity to 8-10%, and to increase extraction of classes of -0,1 mm in a under grate product to 50-55%.

Results are received at overloads (vibroexcitation acceleration to gravity acceleration) about 8-10 g.

Technological indicator increase is possibly at modes with overloads over 10 g. Such accelerations aren't characteristic for serial trammels. Providing such modes demands creation of especially strong designs.

Experience of impulse influence ("single blows") use for an intensification of a loosening, division and dehydration of large particle raw materials [4] is known. Under these conditions for a narrow class of a fineness +0,4-0,63 mm the under grate product output increased to 70% is at humidity decrease of above grate product to 4-5%.

At division and dehydration of raw materials of a wide fineness class the new way of a vibroshock grating large particles weren't applied. Preliminary tests showed prospects of this direction. It is necessary to find out indicator influence of large particles quantity on division and dehydration, and what grating technological results can be reached then.

Due to the above facts, the *work purpose* is the experimental check of a division intensification ways on a fineness and dehydration of raw materials at a new vibroshock grating.

For this purpose there were conducted experiments on the trammel model (fig. 1) consisting of a box 1 under which the beam 2 with an elastic element 3 and drummers 4 (main) and 5 (additional) were established. On elastic laying 6 steel cores 7 on

Dehydration and drying. Water sludge economy

which the grid 8 settled down are mounted. At harmonious excitement of basis 9 the variable force of inertia is affected on the drummer that leads to periodic contact ruptures of the drummer 4 with cores 7. As a result of it the shock impulses which are transmitting through cores to the 7th grid of 8 and processed raw materials 10 are generated. The mode with "double blows" was carried out by means of the additional drummer 5 with rigidity of an elastic element, other than rigidity of an elastic element of the drummer 4. The activator 11 was mounted over a grid 8 at l distance. Disintegrate elements 12 are settled down on the activator 11.

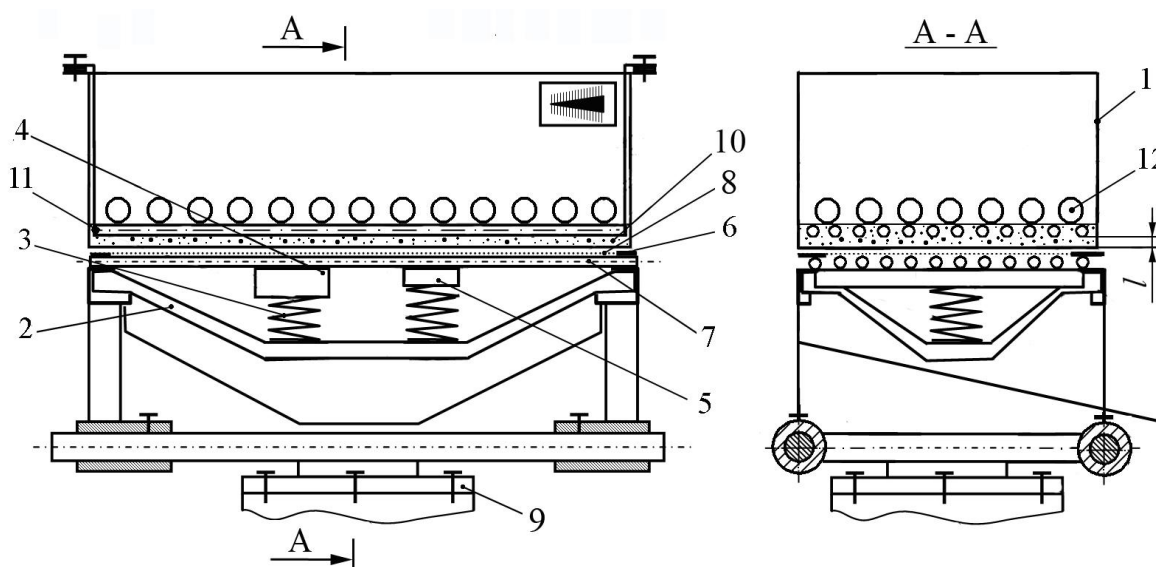
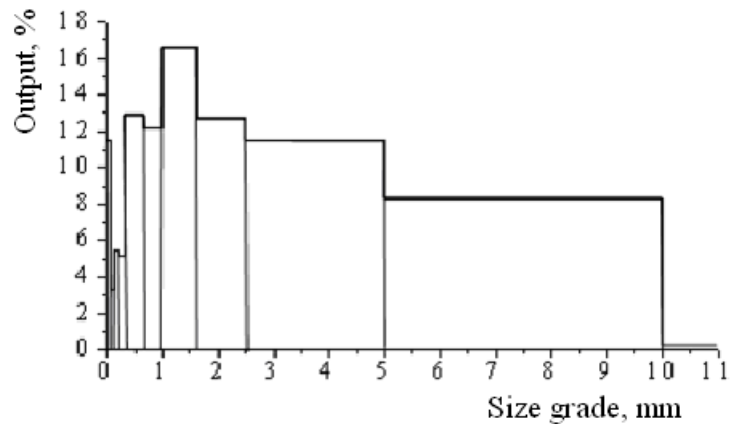

Fig. 1. Trammel model with drummers and the activator:
1 – box; 2 – beam; 3 – elastic element; 4 – main drummer;
5 – additional drummer; 6 – elastic laying; 7 – cores;
8 grid, 9 – basis; 10 – raw materials layer; 11 – activator;
12 – disintegrate elements

Steel cores had length of 308 mm, diameter of 5 mm and a step of installation of 15 mm. Parameters of drummers are: weight is 0,331 kg; rigidity of drummer elastic element is $3 \div 1,23$ kN/m, and rigidity of the additional drummer elastic element is $10 \div 0,7$ kN/m; elastic laying rigidity is 52 kN/m.

Experiments are executed on the metal gauze with 0,1 mm cell and with a 0,1 mm wire diameter.

For researches there was used model mixture (granite elimination – waste of production and granite processing) with sizes of particles of +0-10 mm with the high maintenance of clay particles, granule composition of which is provided on fig. 2. Humidity of an initial product is 30%.



a

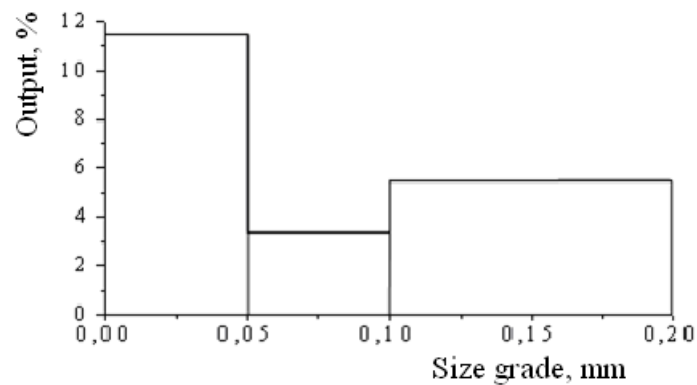

b

Fig. 2. Granule composition material:
a – a fineness interval from 0 to +10 mm;
b– a fineness interval from 0 to 0,2 mm

Experiments were carried out in such sequence:

- the sifting surface was mounted and on l distance from it there was the activator;
- the vibrator turned on, and the demanded amplitude and vibro excitation frequency were established;
- the raw materials moved on sifting surface through the activator;
- the stop watch joined;
- in certain time the vibrator was switched off;
- products were taken and weighed on a sifting surface (above grate), on DE and on the activator
- the under grate product was taken;
- further grating products were exposed to drying and were again weighed.

Division efficiency was estimated on extraction of under grate -0,1 mm class product in comparison with its contents in above grate.

Intensity of dehydration was characterized by the relative amount of water, remained in a above grate product after impulse influence

Dehydration and drying. Water sludge economy

$$W = \frac{m_M - m_c}{m_c} \cdot 100\%, \quad (1)$$

where m_M – the mass of a damp product; m_c – the mass of a dry product.

As DE metal balls and large particles of +5-10,0 mm in size are used. Balls are made of ShH 15 steel and have variable parameters: diameter changes from 10 to 14 mm, weight – from 4,81 to 11,48 g. SBD (specific bulk density) of balls is 26,5 kg/m³. During researches the ratio of the maintenance of large particles c_K to small c_M is varied

Experiments are executed with a frequency of 35,5 Hz, amplitude of 2 mm, time of a grating 180c, distance $l = 2$ mm and various specific feed loadings.

By pilot studies results humidity change graph of above grate and the product class content depending on a ratio of large particles to small c_K/c_M are constructed at specific loadings of 6,25 (fig. 3), 12,5 (fig. 4) and 25 kg/m² (fig. 5).

According to graphs 3-5 use of large particles allows to reduce humidity of a above grate product and to increase under grate extraction.

At increase c_K/c_M from 0 to the 2 humidity decreases from 8-9% to 6-6,5%.

Extraction -0,1 mm class in a under grate product increases from 45-55% to 60-66%.

The greatest grating efficiency (the minimum humidity of above grate and the maximum extraction in an under grate product of -0,1 mm class) is observed at reduction of specific feed loading (fig. 3-5).

At experiments the part of raw materials collected on the activator and DE and circulated in process. Without use of large particles its quantity reached 7-30%. Application of large particles allowed to lower these indicators to 3-7%, and to increase an above grate product output from 70-93 to 93-97%.

Thus, it is established that modes with "double blows" allow to increase extraction of -0,1 mm class to 30-35% at decrease in humidity of an above grate product to 14-15%. Higher rates aren't reached because part of raw materials balls up. Application of DE intensifies a raw materials loosening that's why humidity of an above grate product decreases to 10-12%, and extraction of under grate product of -0,1 mm classes increases to 45-50%. To increase a grating efficiency it is necessary to intensify also a raw material loosening and to overcome forces of a superficial tension for capillary and butt water removal. The new way of a vibroshock grating with use of the activator gives the chance to reduce humidity of a above grate product to 8-10%, and to increase extraction to 50-55% for an under grate product of -0,1 mm classes. Additional conditions for raw material loosening intensification are necessary for further increase of a grating efficiency.

Dehydration and drying. Water sludge economy

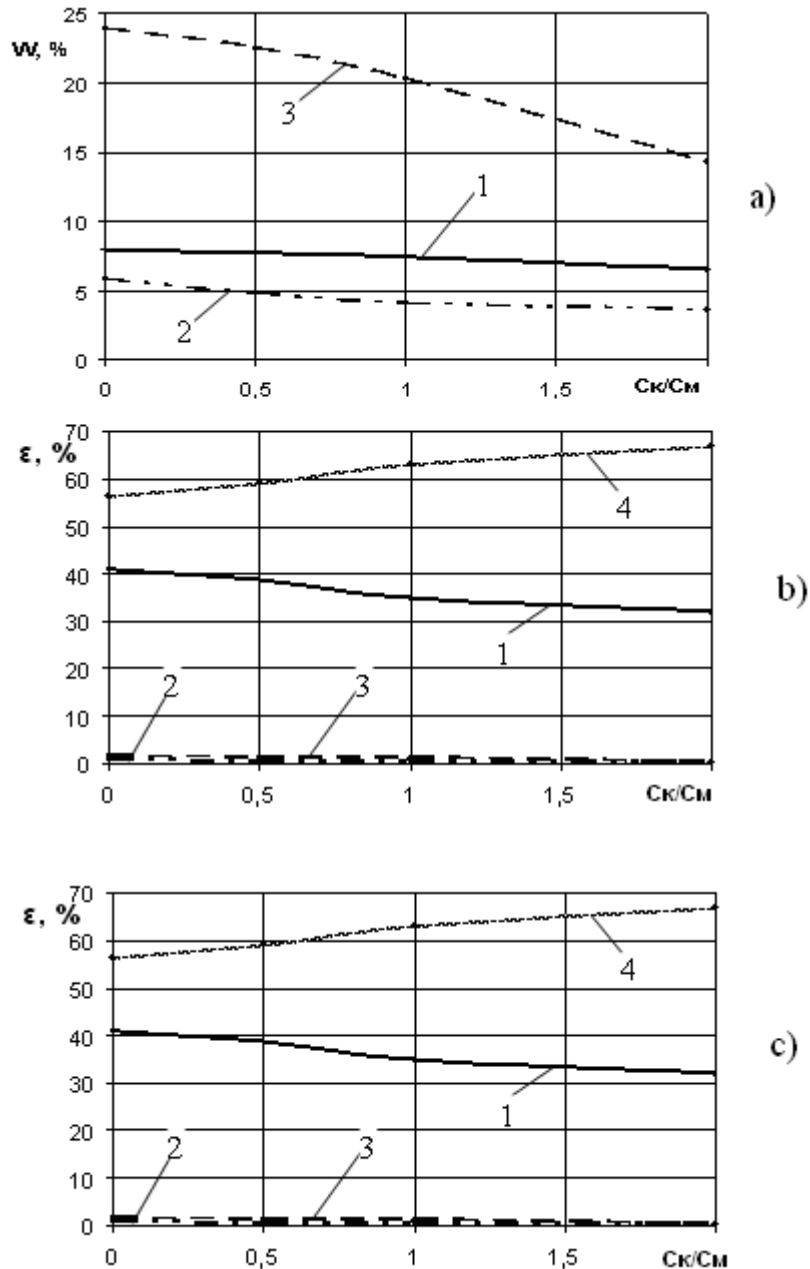

Fig. 3. Humidity change W and extraction ε classes in products depending on quantity ratios of a large material to small c_K/c_M at a grating time 180 s, distance $l = 2$ mm and specific feed loading $6,25 \text{ kg/m}^2$:

a – humidity change W ; b – extraction change ε of 0-0,1 mm class;
c – changes of the +0-10,0 mm class content.

1 – above grate product; 2 – product on the activator; 3 – product on DE;
4 – under grate product

Dehydration and drying. Water sludge economy

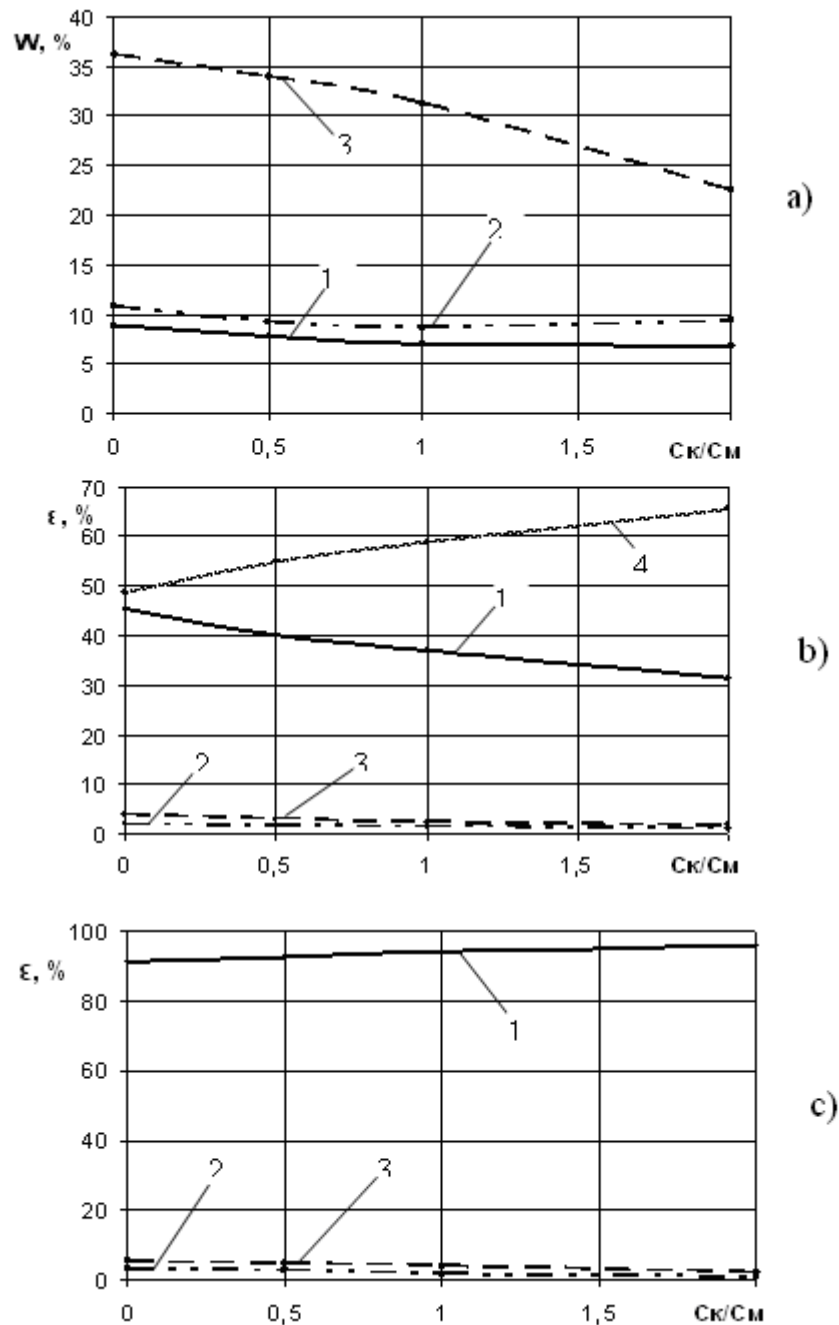

Fig. 4. Humidity change W and extraction ε classes in products depending on quantity ratios of a large material to small c_k/c_M at a grating time 180 s, distance $l = 2$ mm and specific feed loading $12,5 \text{ kg/m}^2$:

a – humidity changes of W ; b– extraction change ε 0-0,1 class;

c –changes +0-10,0 mm class contents

1 – above grate product; 2 – product on the activator; 3 – product on DE;

4 – under grate product

Dehydration and drying. Water sludge economy

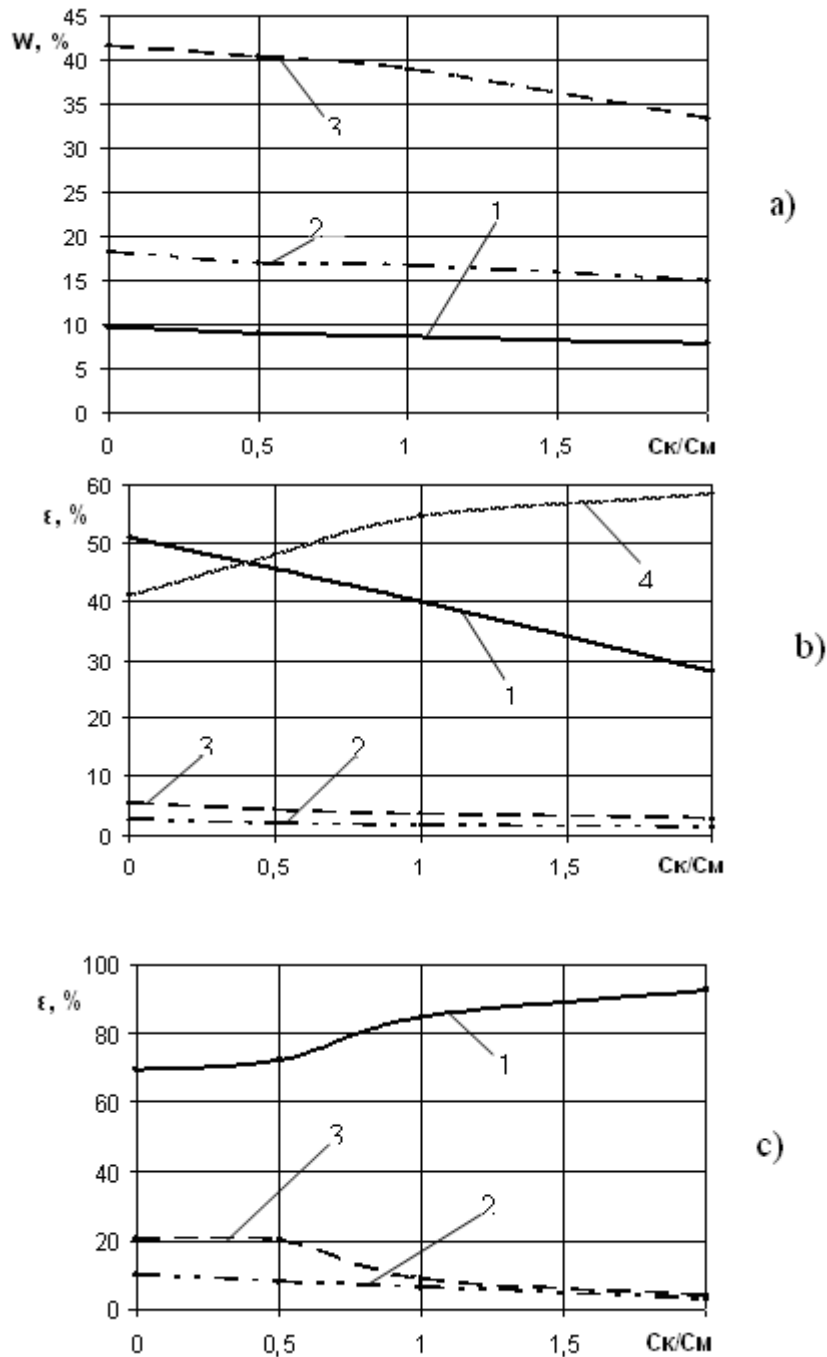

Fig. 5. Humidity change W and extraction ϵ classes in products depending on quantity ratios of a large material to small c_K/c_M at a grating time 180 s, distance $l = 2$ mm and specific feed loading 25 kg/m^2 :
 a – humidity changes of W ; b– extraction change ϵ 0-0,1 class;
 c –changes +0-10,0 mm class contents
 1 – above grate product; 2 – product on the activator; 3 – product on DE;
 4 – under grate product

Addition of large particles to a processed material allows improving division and dehydration indicators. Humidity decreases with 8-9 to 6-6,5% at content ratio of the large particles to small c_K/c_M increasing from 0 to 2 mm, and extraction of

Dehydration and drying. Water sludge economy

- 0,1 mm class in a under grate product increases from 45-55 to 60-66%. Besides, use of large particles allows to reduce the material maintenance on the activator and DE and to increase of an above grate product extraction.

The received results will be used for developing mathematical model of process division on a fineness and dehydration of raw materials, and also at creation of a new vibroshock trammel.

References

1. Повышение эффективности удаления влаги при тонком грохочении горной массы за счет импульсного воздействия / В.П. Надутий, Е.С. Лапшин, А.И. Шевченко и др. // Научно-технический вестник: Наук.-техн. журнал. – 2011. – Вып. 2(122). – С. 95-99.

2. Шевченко А.И. Влияние удельной нагрузки, конструктивных и режимных параметров на интенсивность обезвоживания минерального сырья при вибрационном грохочении // Геотехническая механика: Межвед. сб. науч. тр. – 2012. – Вып. 99. – С. 150-156.

3. Лапшин Е.С., Шевченко А.И. Пути интенсификации обезвоживания минерального сырья на вибрационных грохотах // Збагачення корисних копалин: Наук.-техн. зб. – 2011. – Вып. 47(88). – С. 144-151.

4. Шевченко А.И. Пути повышения эффективности грохочения и обезвоживания минерального сырья на вибрационных грохотах // Геотехническая механика: Межвед. сб. науч. тр. – 2012. – Вып. 97.

5. Пат. № 65469 Україна, МПК В 07В 1/40. Спосіб грохочення та зневоднювання мінеральної сировини, що важко класифікується / Надутий В.П., Лапшин Є.С., Шевченко О.І. ; заявник та патентовласник ІГТМ НАН України. - № у 2011 05325 ; заявл. 26.04.2011 ; опубл. 12.12.2011, Бюл. № 23. – 4 с.

6. Пат. № 67194 Україна, МПК В 07В 1/40. Спосіб грохочення та зневоднювання матеріалів, що важко класифікуються / Надутий В.П., Лапшин Є.С., Шевченко О.І. ; заявник та патентовласник ІГТМ НАН України. - № у 2011 07943 ; заявл. 23.06.2011 ; опубл. 10.02.2012, Бюл. № 3. – 4 с.

7. Пат. № 77362 Україна, МПК В 07В 1/40. Спосіб розділення за крупністю та зневоднювання сипучого матеріалу, який важко класифікується / Надутий В.П., Лапшин Є.С., Шевченко О.І. ; заявник ІГТМ НАН України. - № у 2012 09458 ; заявл. 02.08.2012 ; опубл. 11.02.2013, Бюл. № 3. – 4 с.

© Shevchenko A.I., 2013

*Надійшла до редколегії 17.08.2013 р.
Рекомендовано до публікації д.т.н. Г.О. Шевченком*